

OPERATING MANUAL

SPECIAL TOOL SW42

Torque tester for overload clutches

697028 / ADLS1002 - 3
Date 09.14 | Update 1.2023



**Read and observe this operating manual before the initial commissioning.
Keep this manual for future use.**

IDENTIFICATION DATA

Identification Data

Enter the identification data of the special tool here. The identification data are on the type plate.

Type: _____
Serial number: _____
Year of manufacture: _____

Address of the manufacturer

WALTERSCHEID GmbH
Address: Hauptstraße 150
Town: D-53797 Lohmar
Tel.: + 49 (0) 22 46 12 - 0
website: www.walterscheid.com
E-mail: info@walterscheid.com

Formalities for the operating manual

Creation date: Date 09.14 | Update 1.2023
© Copyright WALTERSCHEID GMBH, 2014
All rights reserved.

Reprints whether in whole or in part are only allowed with the permission of WALTERSCHEID GMBH.



Printed in Germany



**Read and observe this operating manual before the initial commissioning.
Keep this manual for future use.**

Preface

Dear Customer,

You have purchased a quality product from the extensive product range of WALTERSCHEID GMBH. Thank you for your confidence in us.

On receipt of the special tool, establish whether transport damage has occurred or parts are missing. Check the completeness of the supplied special tool including the ordered special equipment using the delivery note. Compensation will only be made if complaints are made immediately.

Read and observe this operating manual, particularly the safety instructions, before the first start-up. You can use the benefits of your newly acquired special tool completely after the careful reading.

Ensure that all operators of the special tool read this operating manual before the special tool is put into operation.

Please contact us if you have any questions about handling the special tool or this operating manual.

Regular maintenance and replacement in good time of worn or damaged parts increase the service life of your special tool.

User Assessment

Dear Reader,

Our operating manuals are updated regularly. Your suggestions for improvement help us to make the operating manual more and more easy to use. Please send us your suggestions by fax or E-mail to:

WALTERSCHEID GMBH

Address: Hauptstraße 150

Town: D-53797 Lohmar

Tel.: + 49 (0) 22 46 12 - 0

E-mail: info@walterscheid.com

CONTENTS

1	User Information	6
1.1	Purpose of the document	6
1.2	Location details in the operating manual	6
1.3	Illustrations used	6
1.4	Terms used	7
2	Product Description.....	8
2.1	Overview – assemblies	9
2.2	Safety devices and protective equipment	11
2.3	Intended use.....	12
2.4	Danger zone and danger points.....	12
2.5	Type plate and CE marking.....	13
2.6	Technical data	13
2.7	Conformity	14
3	Safety Instructions.....	15
3.1	Safety-conscious working	15
3.2	Organisational measures	16
3.2.1	Obligations of the owner	16
3.2.2	Obligations of the operator	17
3.2.3	Qualification of the persons	18
3.3	Product Safety.....	20
3.3.1	Safe operation of the special tool	20
3.3.2	Safety devices and protective equipment.....	20
3.3.3	Structural changes	20
3.3.4	Spare and wear parts and auxiliary materials	21
3.3.5	Warranty and liability.....	21
3.4	Basic safety instructions.....	22
3.4.1	General safety and accident prevention instructions.....	22
3.4.2	Hydraulic system.....	23
3.4.3	Cleaning, maintenance and repairs	24
3.5	Action-related safety instructions and important information	25
3.5.1	Action-related safety instructions	25
3.5.2	Important information	26
3.6	Warning signs and instruction signs.....	27
3.6.1	Warning signs	27
3.6.2	Instruction signs	30
3.6.3	Placement of the warning signs and instruction signs.....	31
3.7	Hazards in the case of non-observance of the safety instructions and warning signs	32
4	Preparing Special Tool for Use.....	33
4.1	Transport	33
4.2	Unpacking	34
4.3	Scope of delivery / equipment.....	35
5	First Start-up	36
5.1	Connecting hydraulic hose lines of the gearbox to the connections of the hydraulic drive	37
5.2	Connecting power supply	38
5.3	Installing "SW42 Analysis2_0" program.....	39
5.3.1	System requirements	39
5.3.2	Installing the program as follows	39
5.3.3	Setting up computer to receive incoming Bluetooth connections	40

6	Setting up Special Tool	42
6.1	Inserting / removing profile pins in / from measuring hub.....	42
6.2	Selecting torque support / torque flange mounting.....	44
6.3	Operating special tool using two-hand control.....	46
7	Attaching Overload Clutch on Profile Pin and Securing	47
7.1	Overload clutch with yoke.....	47
7.2	Overload clutch without yoke.....	49
8	Testing Functionality of Overload Clutches	50
8.1	Testing friction clutches.....	51
8.2	Testing radial pin and cam-type cut-out clutches.....	52
8.3	Measuring torque on a friction clutch, radial pin clutch or cam-type cut-out clutch.....	52
8.3.1	Switching on measuring hub.....	52
8.3.2	Starting the "SW42 Analysis2_0" program.....	53
8.3.3	Selecting language and inputting company details.....	53
8.3.4	Selecting COM connection for receiving incoming Bluetooth connections.....	54
8.3.5	Entering and/or selecting customer, implement and clutch details.....	55
8.3.6	Conducting a zero point adjustment of the measuring hub.....	56
8.3.7	Attaching overload clutch on profile pin and securing.....	56
8.3.8	Starting special tool SW42 for the measurement and performing measurement ..	56
8.3.9	Measured data – recording and analysis.....	58
8.3.10	Stopping special tool SW42.....	59
8.3.11	Saving measurement report as PDF file.....	60
9	Errors While Testing the Functionality of an Overload Clutch	61
9.1	Bluetooth connection is not established.....	61
9.2	Bluetooth connection is lost during the measurement.....	62
9.3	Nominal value for the required torque is not reached.....	62
9.4	The "SW42 Analysis2_0" program ends suddenly.....	63
10	Cleaning, Maintenance and Repairs	64
10.1	Removing and installing measuring hub.....	64
10.1.1	Removing measuring hub.....	64
10.1.2	Installing measuring hub.....	66
10.2	Charging battery of the measuring hub.....	68
10.3	Replacing battery of the measuring hub.....	69
10.4	Checking oil level.....	70
11	EC Declaration of Conformity	71
12	Spare Parts List	72
12.1	Frame.....	72
12.2	Counter bearing.....	73
12.3	Hydraulics.....	74
12.4	Hydraulic unit SW42.....	75
12.5	Controller.....	76
12.6	Parts list.....	77

USER INFORMATION

1 User Information

The User Information chapter provides information about using the operating manual.

1.1 Purpose of the document

The present operating manual:

- describes the operation and maintenance for the special tool.
- provides important information for safe and efficient handling of the special tool.
- is an integral part of the special tool and must always be kept accessible in the vicinity of the special tool.
- must be kept for future use.
- must be passed on to the purchaser if the special tool is sold.

1.2 Location details in the operating manual

All direction statements in this operating manual are always in the direction of the front side of the special tool. The reversible thread adapter is always on the left here.

1.3 Illustrations used

Handling instructions and reactions

Activities to be performed by the operator are shown as numbered instructions. Comply with the sequence of the specified instructions. The reaction to the respective instruction is marked by an arrow if necessary. Example:

1. Instruction 1
→ Reaction of the special tool to instruction 1
2. Instruction 2

Lists

Lists without a mandatory sequence are shown as a list with bullet points. Example:

- Point 1
 - Point 2
-

Position numbers in figures

Numbers in round brackets refer to position numbers in figures. The first number refers to the figure and the second number to the position number in the figure.

Example (Fig. 3/6)

- Figure 3
- Position 6

1.4 Terms used

The term ...	means ...
Third party	... all persons except the operator.
Hazard	... the source of a possible injury or harm to health.
Manufacturer	... the company WALTERSCHEID GMBH.
Control	... the part which is directly operated by the operator, e.g. by pressing. A control can be a control lever, rocker switch, button, rotary switch etc.

PRODUCT DESCRIPTION

2 Product Description

This chapter contains:

- comprehensive information about the design of the WALTERSCHEID special tool SW42,
- the names of the individual assemblies and controls.

If possible, read this chapter directly at the special tool. This will best familiarise you with the special tool.

2.1 Overview – assemblies

Illustration of the special tool SW42 and designation of the most important elements.

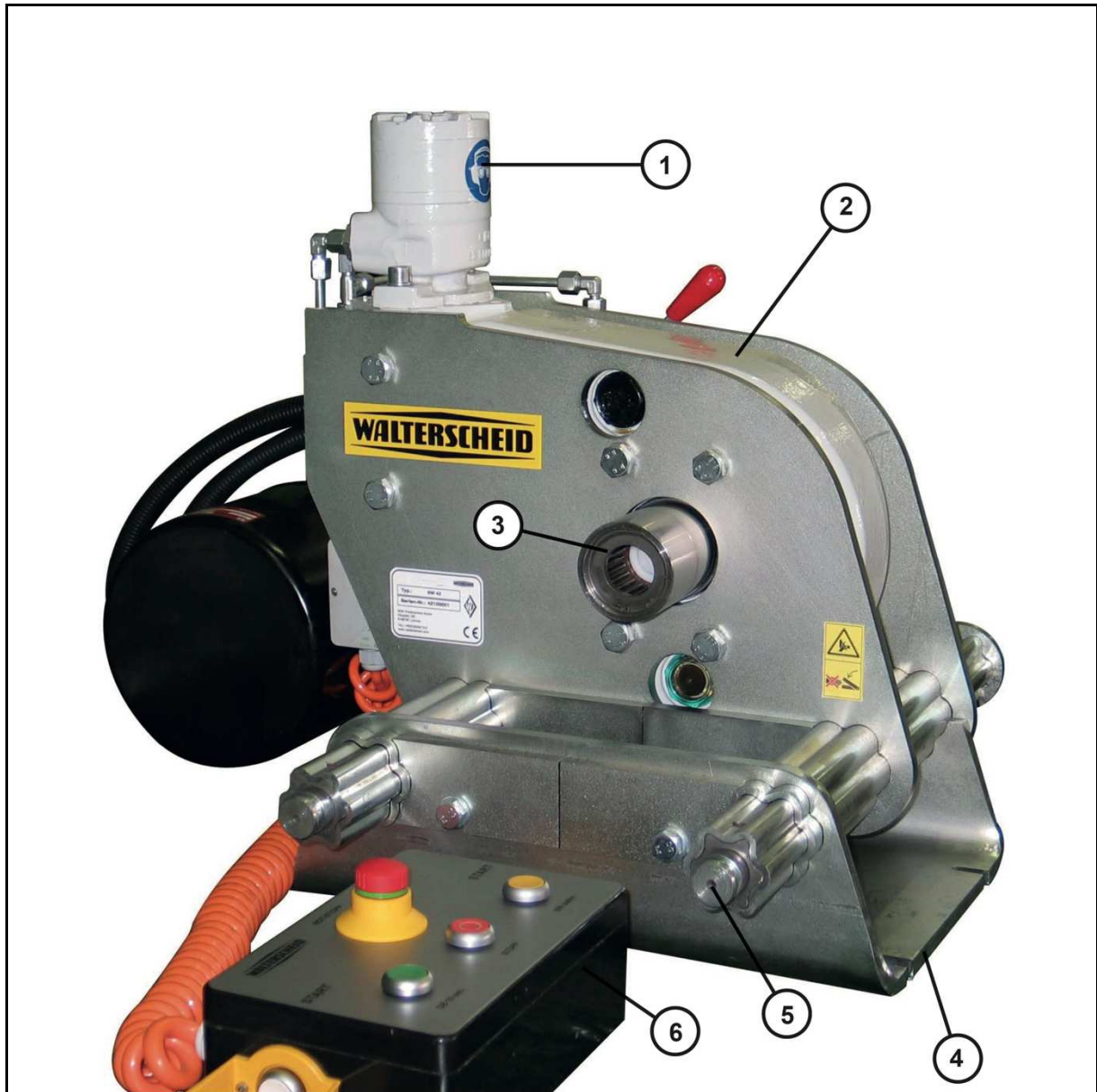

Fig. 1

- (1) Hydraulic motor
- (2) Gearbox
- (3) Measuring hub, for holding various profile pins
- (4) Base
- (5) Carriage, for holding the torque support
- (6) Two-hand control

PRODUCT DESCRIPTION

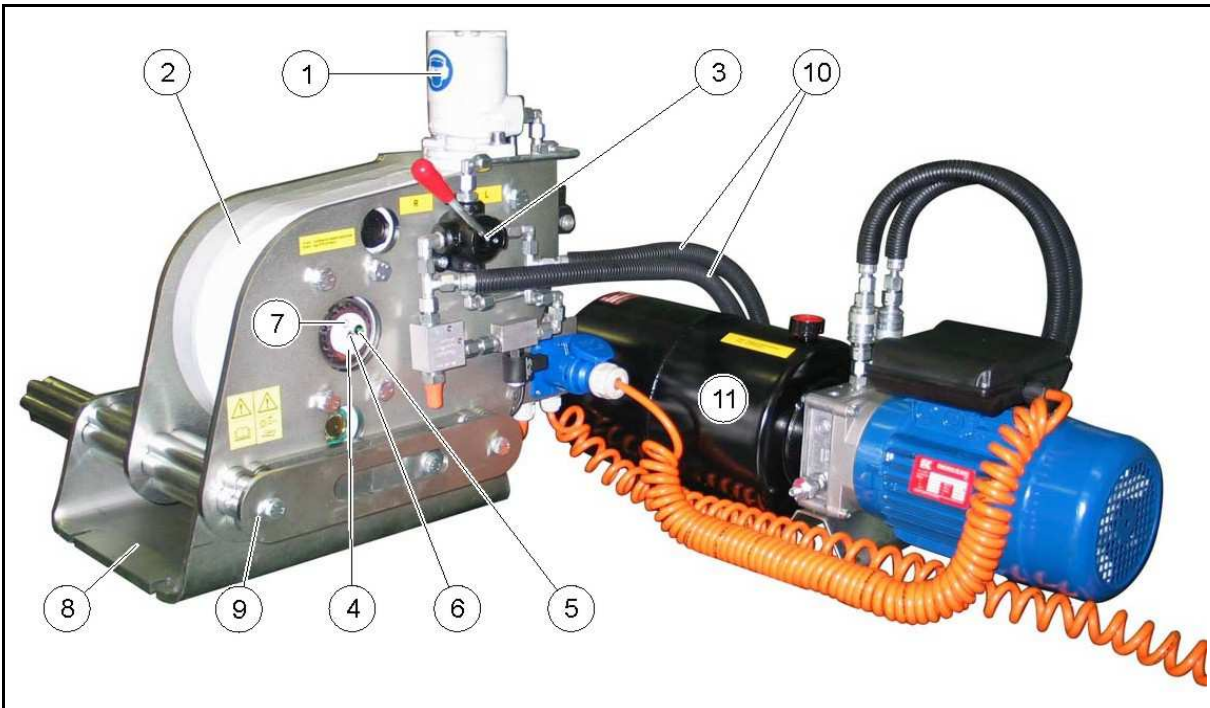

Fig. 2

- (1) Hydraulic motor
- (2) Gearbox
- (3) Changeover valve for tester rotation direction (of the measuring hub)
- (4) Measuring hub
- (5) ON / OFF switch with green LED lamp lights when measuring hub is switched on
- (6) DC input for charging the measuring hub battery
- (7) LED lamp for battery charge status lights when battery is discharged
- (8) Base
- (9) Carriage
- (10) Hydraulic hose lines with protective tube
- (11) Hydraulic unit (optional)

2.2 Safety devices and protective equipment

This chapter shows the arrangement of the correctly mounted safety devices and protection equipment in the safety position.

WARNING



Hazards for persons can arise from ejected objects if the required safety devices and protection equipment are not present during operation!

- Only put the special tool into operation when safety devices and protective equipment are completely installed.
- Replace defective safety devices and protective equipment immediately with new ones.

(1) Two-hand control

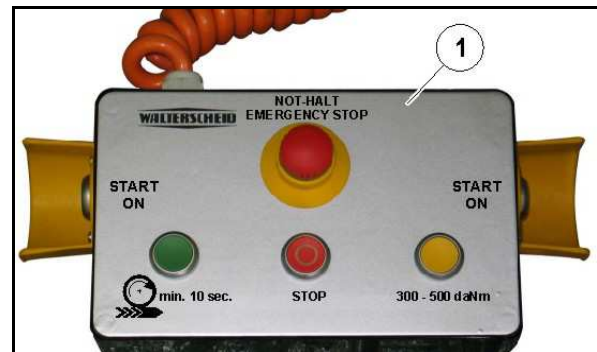

Fig. 3

(2) Protective tube on the respective hydraulic hose line to the hydraulic unit

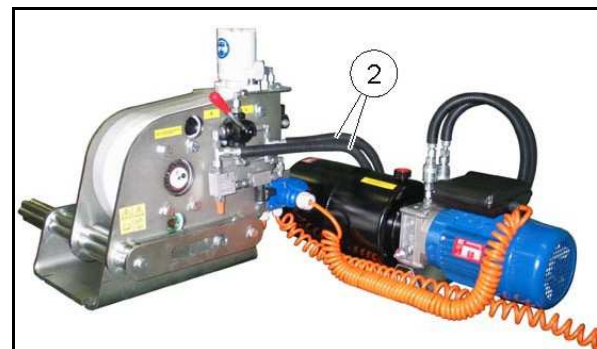

Fig. 4

PRODUCT DESCRIPTION

2.3 Intended use

The WALTERSCHEID special tool SW42 is exclusively intended for testing the functionality of overload clutches during repairs, reassembly or adjustment by qualified skilled personnel. Overload clutches with a maximum torque of up to 500 daNM (5000 Nm) can be tested.

Intended use also includes:

- compliance with all instructions in this operating manual,
- compliance with the specified work for maintenance and care of the special tool,
- the exclusive use of original parts.

Any uses other than those above are prohibited and are deemed as non-intended use.

For damage arising from non-intended use:

- the owner bears the sole responsibility,
- the manufacturer accepts no liability of any kind.

2.4 Danger zone and danger points

The danger zone is the area between the mounted overload clutch and the mounted torque support in which hazards for the safety or health of persons arise when the test process is started.



No persons must reach into the danger zone during the start of the test process.

The operator is only permitted to start the test process if no persons are present in the danger zone.

There are hazards in the danger zone from danger points which cannot be completely eliminated with respect to the functional safety of the special tool. The hazards are always present.

Danger points on the special tool are identified with warning signs. The warning signs warn about the residual risks.

Action-related safety instructions in this operating manual indicate the existing residual risks of the special tool.

2.5 Type plate and CE marking

The following illustration shows the layout of the type plate and CE marking.

	The complete marking has official status and must not be modified or rendered unrecognisable.
---	---

The type plate shows:

- Type
- Serial No.
- Manufacturer
- Connected loads

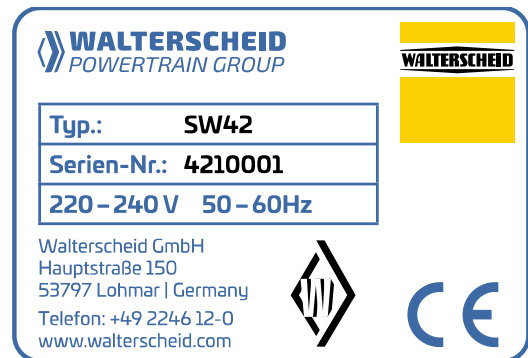

Fig. 5

2.6 Technical data

Tester		
Weight:	kg	160
Dimensions:		
• Length		700
• Width	mm	600
• Height		600
Gearbox oil:		SAE 90 GL 4
Test speed:	rpm	Setpoint 2.5 (1.5 to 4 permissible)
Hydraulic unit (if included in the order)		
Weight:	kg	30
Dimensions:		
• Length		600
• Width	mm	300
• Height		270
Hydraulic oil:		HLP 46
Maximum operating pressure:	bar	150
Flow rate:	l/min	6±2
Electric motor:		
• Voltage:	Volt	220 – 240 V (50 – 60 Hz)
• Power:	W	1,500

PRODUCT DESCRIPTION

2.7 Conformity

The WALTERSCHEID special tool SW42 for checking the functionality of overload clutches during repair, reassembly or adjustment complies with the basic health and safety requirements of the following Directive and standards:

- Directive 2006/42/EC
- EN ISO 12100:2010
- EN ISO 4413:2010
- EN 574:1996+A1:2008

The manufacturer confirms that the Special Tool SW42 complies with the basic health and safety requirements:

- by the issue of the declaration of conformity,
- by the application of the CE marking to the special tool.

In the case of non-approved structural changes and attachments or conversions:

- the declaration of conformity and the CE marking of the special tool lose their validity,
- warranty claims and liability claims for personal injuries and damage to property are excluded by the manufacturer,
- the owner bears the responsibility.

3 Safety Instructions

This chapter contains important information for the owner and the operator about the safe and faultless operation of the special tool.



Comply with all safety instructions in this operating manual.

Most accidents are caused by non-observance of the simplest safety regulations.

You help to prevent the occurrence of accidents by observing all the safety instructions in this operating manual.

3.1 Safety-conscious working

The special tool has been built in accordance with the state of the art and the generally recognised rules of technology. Nevertheless, hazards and adverse effects can arise during use of the special tool:

- for the life and limb of the operator or third persons,
- for the special tool itself,
- to other property.

Observe the following for the safe operation of the special tool:

- this operating manual, particularly:
 - the basic safety instructions, the action-related safety instructions and the action instructions,
 - the information about intended use.
- the warnings on the special tool,
- the national, generally applicable regulations for occupational health and safety, accident prevention and environmental protection.

Only operate the special tool when it is in a technically faultless condition.

SAFETY INSTRUCTIONS

3.2 Organisational measures



The operating manual:

- always keep at the usage location of the special tool,
- must be freely accessible at any time to the operator and maintenance personnel.

3.2.1 Obligations of the owner

The owner is obligated:

- to comply with the national, generally applicable regulations for occupational health and safety, accident prevention and environmental protection,
- to only allow persons to work with/on the special tool who:
 - are familiar with the basic requirements for occupational health and safety and accident prevention,
 - have been instructed about working with/on the special tool,
 - have read and understood this operating manual.
- to keep all warning signs on the special tool in legible condition,
- to replace damaged warning signs,
- to provide the required personal protective equipment, such as:
 - safety goggles,
 - work gloves according to DIN EN 388,
 - safety footwear,
 - protective clothing,
 - barrier cream, etc.

3.2.2 Obligations of the operator

All persons who are assigned to working with/on the special tool are obliged, before starting work:

- to comply with the national, generally applicable regulations for occupational health and safety, accident prevention and environmental protection,
- to read and observe the chapter "Basic safety instructions" starting on page 22 of this operating manual,
- to read the chapter "Warnings and instructions" starting on page 27 of this operating manual and to observe the warnings during operation of the special tool,
- to familiarise themselves with the special tool,
- to read the chapters of this operating manual which are important for carrying out the work assigned to them.

If the operator discovers that the equipment is not technically safe, the operator must rectify this defect immediately. If this is not part of the operator's work assignment or he does not have the corresponding technical knowledge, the operator must notify the defect to his supervisor or the owner.

SAFETY INSTRUCTIONS

3.2.3 Qualification of the persons



Only trained and instructed persons are permitted to work with / on the special tool. The owner must clearly specify the responsibilities for operation, maintenance and repairs.

A person undergoing training is only permitted to work with / on the special tool under the supervision of an experienced person.

The owner is only permitted to carry out the work described in this operating manual.

Only specialist workshops are permitted to carry out work on the special tool which requires particular technical knowledge. Specialist workshops have qualified personnel and suitable auxiliary equipment (tools) for the proper and safe performance of this work.

This applies to all work:

- which is not mentioned in this operating manual,
- which is identified with the addition of "workshop work" in this operating manual.

Activity \ Persons	Person specially trained for the activity ¹⁾	Instructed person ²⁾	Persons with specialist training (specialist workshop) ³⁾
Loading / Transport	X	X	X
Start-up	--	X	X
Installation, setting up	--	X	X
Operation	--	X	X
Cleaning, maintenance and repairs	--	X	X
Troubleshooting and fault clearance	--	X	X
Disposal	X	--	--

Legend:

X..allowed

--..not allowed

- 1) A person who can take over a specific task and is permitted to perform this for a correspondingly qualified company.
- 2) An instructed person is a person who has been instructed and if required trained about the tasks assigned to him and possible dangers in the case of improper behaviour and who has been instructed about the necessary safety devices, protective equipment and safety precautions.
- 3) Persons with specialist training are skilled persons (specialists). On the basis of their professional training and knowledge of the relevant conditions, they can assess the work assigned to them and recognise possible dangers.

Note: An equivalent qualification to technical training can also be acquired by several years of experience in the work area concerned.

SAFETY INSTRUCTIONS

3.3 Product Safety

3.3.1 Safe operation of the special tool

Only one person is permitted to operate the machine if there are no other persons in the danger zone of the special tool. See also the chapter "Danger zone and danger points", page 12.

3.3.2 Safety devices and protective equipment

- Only operate the special tool if all safety devices and protective equipment have been installed properly and are completely functional.
Defective or removed safety devices and protective equipment can result in dangerous situations.
- Check all safety devices and protective equipment for externally recognisable damage and functionality before you put the special tool into operation.

3.3.3 Structural changes

- Structural changes, attachments or conversions to the special tool must only be made with the manufacturer's written permission.
- In the case of non-approved structural changes, attachments or conversions, the declaration of conformity and the CE marking of the special tool lose their validity.
- Only use original parts or conversion and accessory parts approved by the manufacturer so that:
 - the declaration of conformity and the CE marking of the special tool retain their validity,
 - the faultless function of the special tool is guaranteed.
- The manufacturer shall not be liable for damage caused by:
 - unauthorised modifications of the special tool,
 - non-approved conversion and accessory parts,
 - welding and drilling work on load-bearing parts of the special tool.

3.3.4 Spare and wear parts and auxiliary materials

Replace defective parts immediately.

Only use original parts from the manufacturer or parts approved by the manufacturer for this. If spare and wear parts from third party manufacturers are used, it is not guaranteed that they have been designed and produced in accordance with load and safety.

The manufacturer accepts no liability for damage caused by the use of non-approved spare and wear parts or auxiliary materials.

3.3.5 Warranty and liability

Our "General Terms of Sale and Delivery" always apply. These have been issued to the owner at the latest on conclusion of the contract.

Warranty and liability claims for personal injuries and damage to property are void if they are attributable to one or more of the following causes:

- non-intended use of the special tool,
- incorrect installation, commissioning, operation and maintenance of the special tool,
- operation of the special tool with defective safety devices and protective equipment or incorrectly installed or non-functional safety devices and protective equipment,
- non-observance of the instructions in the operating manual concerning start-up, use and maintenance,
- unauthorised structural changes to the special tool,
- inadequate monitoring of parts which are subject to wear,
- incorrectly carried out repairs,
- catastrophes due to external influences and force majeure.

SAFETY INSTRUCTIONS

3.4 Basic safety instructions

Basic Safety Instructions:

- always apply for the safe operation of the special tool,
- are compiled in the following subchapters.

3.4.1 General safety and accident prevention instructions

- In addition to the safety instructions in this chapter, also comply with the generally applicable safety and accident prevention regulations.
- Always wear your personal protective equipment when working on the special tool.
- Observe the warning notices and instructions applied to the special tool. In this way, you obtain important information for the safe and faultless operation of the special tool.
- In addition to the basic safety instructions in this chapter, also comply with the action-related safety instructions of the other chapters.
- Send any people out of the close vicinity of the special tool before you put it into operation. Pay particular attention to children.

Use of the special tool

- Before starting work, familiarise yourself with all the equipment and controls and their functions of the special tool. During the work is too late for this.
- Only put the special tool into operation when all safety devices and protective equipment are installed.
- It is prohibited for persons to be in the work / danger zone of the special tool.
- There are crushing and shearing points on moving parts of the special tool which are operated by external force.
- You are only permitted to actuate parts of the special tool operated by external force if there are no persons in the danger zone of the special tool.

3.4.2 Hydraulic system

The hydraulic system is under high pressure.

- Before working on the hydraulic system:
 - depressurise the hydraulic system,
 - disconnect the hydraulic system from the external energy source.
- Arrange for the hydraulic hose lines to be checked at least once per year by an expert for their safe working condition.
- Replace the hydraulic hose lines in the case of obvious defects, damage and ageing. Only use original hydraulic hose lines.
- Hydraulic hose lines must not be used for longer than six years including any storage time of maximum two years. Hoses and hose connections are also subject to natural ageing with proper storage and permissible load, thus their storage time and usage period are limited. However, the usage period can be established in accordance with experience values, in particular taking account of the hazard potential. The same guide values apply for hoses and hydraulic hose lines made of thermoplastics.
- Never try to seal leaking hydraulic hose lines with your hand or fingers.
Highly pressurised liquid (hydraulic oil) can penetrate the skin into the body and cause severe injuries.
Contact a doctor immediately in the case of injuries caused by hydraulic oil. Risk of infection!
- Never track down leaks with your bare hands due to the possible high risk of infection. Use suitable aids for the search for leaks (cleaning spray, special leak detection spray).

SAFETY INSTRUCTIONS

3.4.3 Cleaning, maintenance and repairs

- Carry out the specified work for cleaning, maintenance and repairs at the specified intervals.
- Any mechanical, hydraulic or pneumatic residual energies present can initiate unintended movements of the special tool.

Note the presence of residual energies in the special tool for maintenance and repair work. Warning signs identify components with residual energies. Detailed information can be found in the respective chapters of this operating manual.

- Secure all operating media such as hydraulic oil and compressed air against unintended start-up.
- Check the tightness of bolts and nuts regularly. Tighten loosened bolts and nuts.
- Check whether screw connections loosened for cleaning, maintenance and repairs have been tightened again.
- Check the function of safety devices and protective equipment after completion of the maintenance work.
- Dispose of oils, greases and filters properly.
- Handle and dispose of substances and materials used for cleaning the special tool properly, particularly:
 - for work on lubrication systems and equipment,
 - when cleaning with solvents.
- Spare parts must comply at least with the specified technical requirements of the manufacturer. This is always the case when original parts are used.
- Comply with the intervals for the maintenance of wear parts.

3.5 Action-related safety instructions and important information

The operating manual contains action-related safety instructions and important information. Signal words and symbols are used to be able to recognise action-related safety instructions and important information at a glance.

3.5.1 Action-related safety instructions

Action-related safety instructions:

- warn about residual risks which can occur in a specific situation or in connection with a certain action,
- are in the individual chapters immediately before a hazardous activity,
- are identified using the triangle safety symbol and a preceding signal word. The signal word describes the severity of the threatening hazard.

<p>DANGER</p> 	<p>DANGER</p> <p>indicates a direct hazard with high risk which results in severe physical injuries (loss of parts of the body or long-term damage) or death if it is not avoided.</p> <p>There is a direct danger of severe physical injuries including death due to the non-observance of safety instructions marked with "DANGER".</p>
--	--

<p>WARNING</p> 	<p>WARNING</p> <p>indicates a potential hazard with medium risk which can result in severe physical injuries or death if it is not avoided.</p> <p>There is a risk under certain circumstances of severe physical injuries including death due to the non-observance of safety instructions marked with "WARNING".</p>
---	---

<p>CAUTION</p> 	<p>CAUTION</p> <p>indicates a potential hazard with low risk which can result in minor or medium physical injuries or damage to property if it is not avoided.</p> <p>There is a risk under certain circumstances of minor or medium physical injuries or damage to property due to the non-observance of safety instructions marked with "CAUTION".</p>
---	---

SAFETY INSTRUCTIONS

3.5.2 Important information

Important Information:

- provides information for proper handling of the special tool,
- provides user tips for optimum use of the special tool,
- is marked with the symbols below.



IMPORTANT

indicates an obligation for a specific action or activity for the proper handling of the special tool.

The non-observance of this information can result in faults on the special tool or disturbances in the environment.



NOTE

indicates user tips and particularly useful information.

This information can help you to use all functions on your special tool optimally.

3.6 Warning signs and instruction signs

3.6.1 Warning signs



There are warning signs attached to the special tool. Warning signs indicate danger points on the special tool and warn about residual risks which can occur in a specific situation or in connection with a certain action.

Always keep these warning signs in a clean and legible condition. Replace illegible signs. Request the warning signs from your dealer using the part number.

A warning sign consists of 2 pictograms:

(1) Pictogram for the description of the hazard

The pictogram shows the pictorial description of the hazard, surrounded by a triangular safety symbol.

(2) Pictogram for prevention of the hazard

The pictogram shows the pictorial instruction for preventing the hazard.

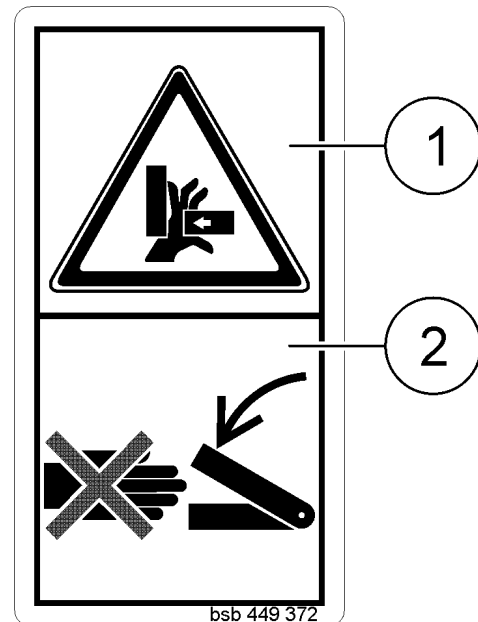

SAFETY INSTRUCTIONS

Explanations of the warning signs

The following list contains:

- all the warning signs present on the special tool in the right-hand column,
- the following information about the warning sign on the right in the left-hand column:
 1. The part number.
 2. The description of the hazard, e.g. "Crushing hazard for fingers or hands when moving the mounting carriage by the approach of moving parts to stationary parts!"
 3. The consequences for ignoring the instruction(s) for prevention of the hazard, e.g. "These hazards can cause severe injuries with loss of parts of the body"
 4. The instruction(s) for preventing the hazard, e.g. "Never reach into the dangerous place while parts can still move". Send any third persons out of the danger zone of the special tool before you move the mounting carriage or start the testing process".

Part number and description

SW42-054

Read and observe the operating manual and safety instructions before you put the special tool into operation.

Warning sign

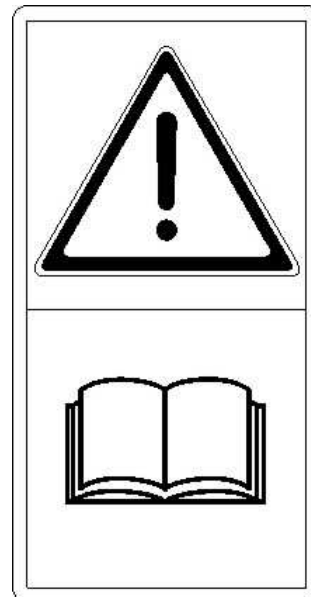

SW42-054**Crushing hazard for fingers or hands caused by accessible moving parts of the machine.**

This hazard can cause severe injuries with loss of parts of the body.

- Never reach into the dangerous place while parts of the machine can still move.
- Send persons out of the danger zone before you operate the two-hand control.

**SW42-054****Hazards during interventions at the machine such as work for mounting, adjustment, fault clearance, cleaning, servicing and repairs.**

These hazards can cause severe injuries including death.

- Secure the machine against unintended starting before all interventions on the machine.
- Depending on the intervention, read and observe the instructions of the corresponding chapter in the operating manual.

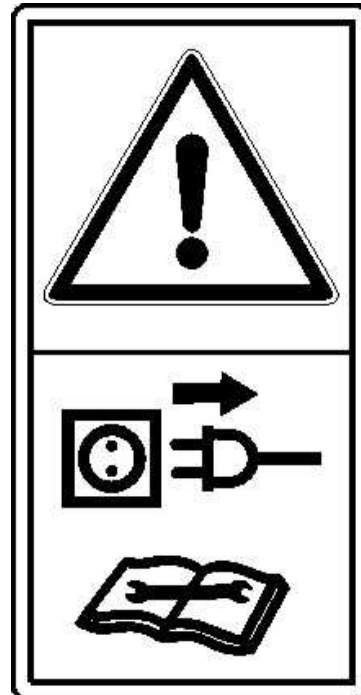

SAFETY INSTRUCTIONS

3.6.2 Instruction signs

An instruction sign consists of a pictogram:

(1) Pictogram with information about proper handling of the machine.

The pictogram contains the information in pictorial or descriptive illustration or in table form.



Part number and description

Instruction sign

SW42-054

Wear hearing and eye protection.



3.6.3 Placement of the warning signs and instruction signs

The following illustrations show the arrangement of the warning signs and instruction signs on the special tool.

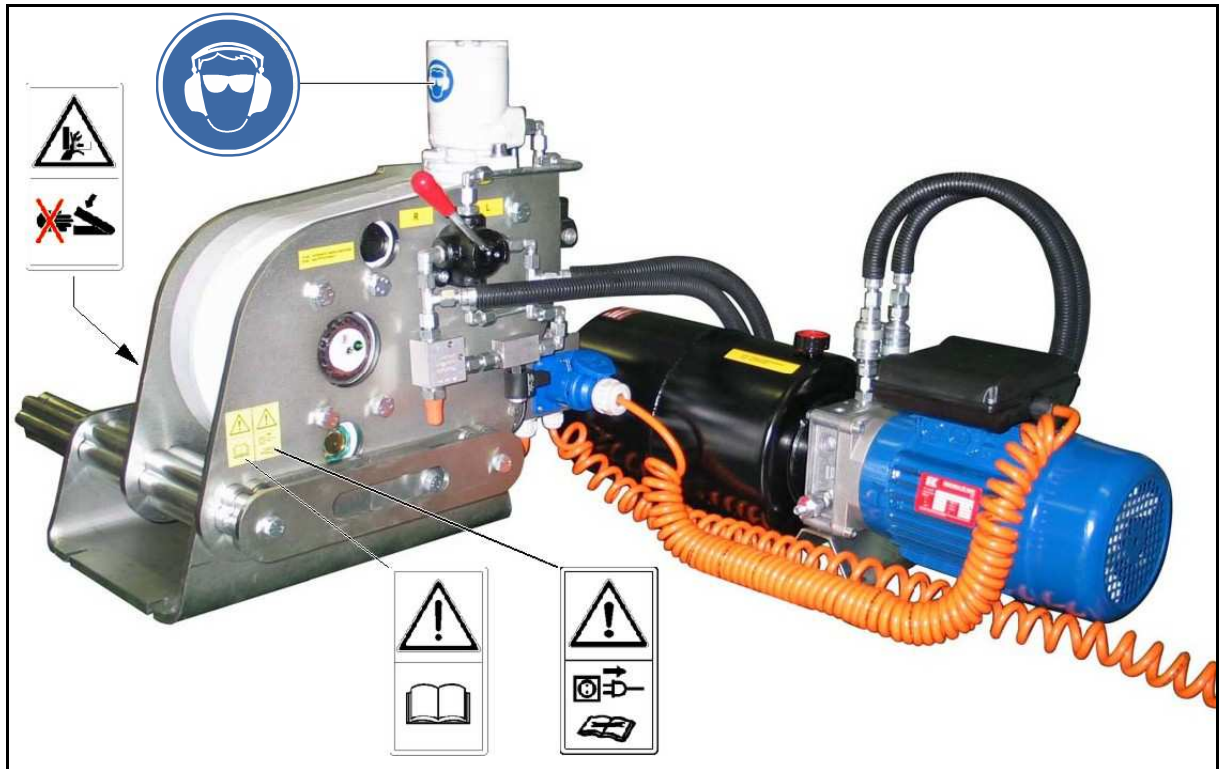

Fig. 6

SAFETY INSTRUCTIONS

3.7 Hazards in the case of non-observance of the safety instructions and warning signs

The non-observance of the safety instructions and warning signs can:

- cause hazards for persons, environment and special tool such as:
 - hazards to persons caused by unsecured work areas,
 - failure of important functions of the special tool,
 - failure of specified methods for the maintenance and repair,
 - hazard to persons caused by mechanical and chemical effects.
- result in the voidance of any claims for compensation.

4 Preparing Special Tool for Use

4.1 Transport

The special tool SW42 and the hydraulic unit SW42 are delivered in closed wooden crates.

The wooden crates can be transported with a forklift or suitable lifting gear.



Fig. 7



Fig. 8

PREPARING SPECIAL TOOL FOR USE

4.2 Unpacking



A suitable hoist (Fig.9/1) is required for unpacking the special tool SW42. Attach the lifting sling (Fig.9/2) to the provided stud bolt (Fig.9/3).

1. Undo and remove the fixing screws of the cover.
2. Undo and remove the fixing screws of the parts screwed to the wooden case.
3. Remove all parts from the wooden case.
4. Set the special tool down on a stable work surface.

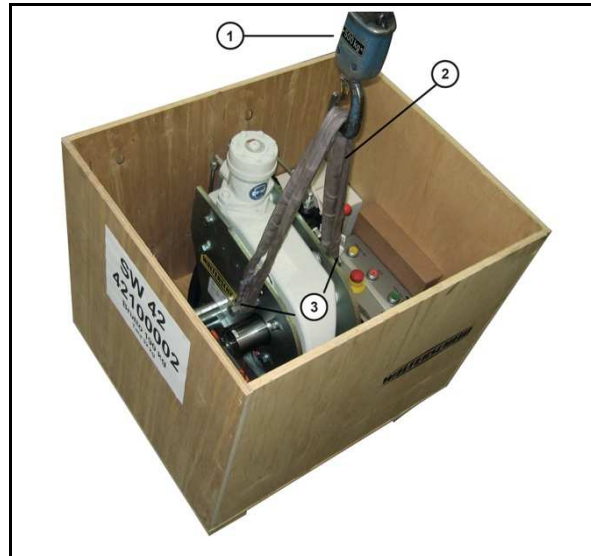

Fig.9



At least two persons are required for unpacking the hydraulic unit SW42.

1. Undo and remove the fixing screws of the cover.
2. Undo and remove the fixing screws of the parts screwed to the wooden case.
3. Remove all parts from the wooden case.
4. Set the hydraulic unit down on a stable work surface or on the floor.



Fig. 10

4.3 Scope of delivery / equipment

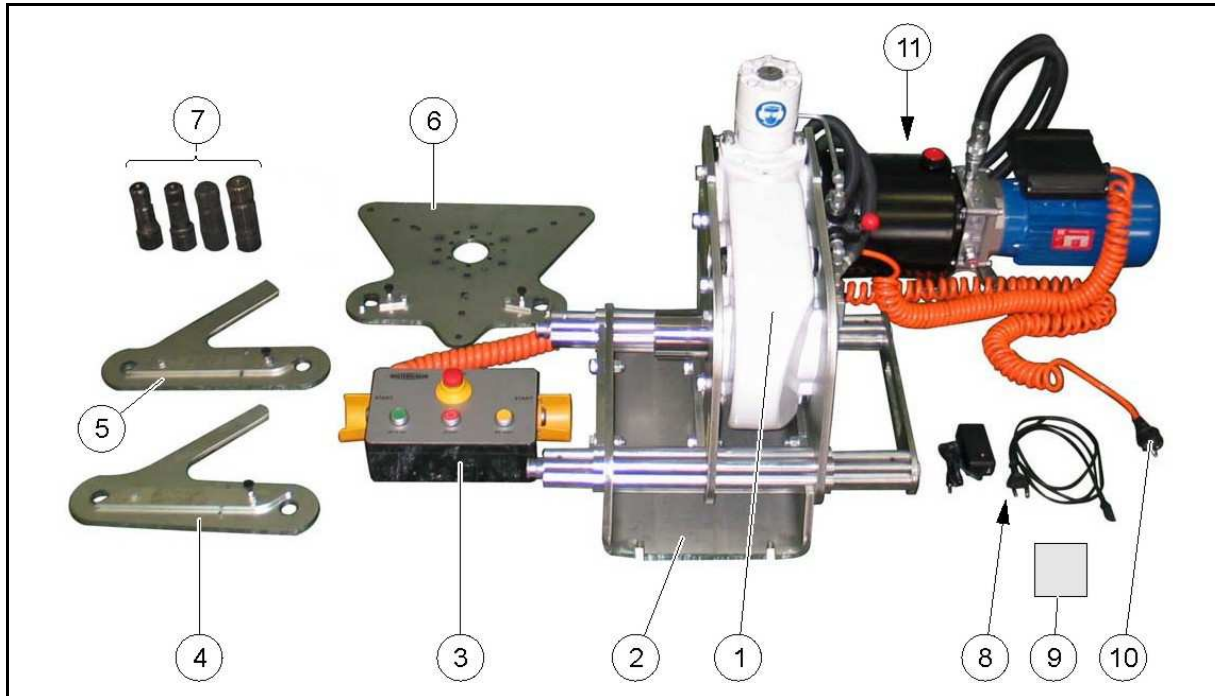

Fig. 11

- (1) Gearbox with measuring hub, hydraulically driven
- (2) Base with carriage
- (3) Two-hand control
- (4) Torque support 300 daNm
- (5) Torque support 500 daNm
- (6) Torque flange mounting
- (7) Profile pins
- (8) Power supply for measuring hub battery
- (9) One CD-ROM with the SW42 Analysis2_0 software
- (10) Mains connection cable
230 volts / 50 Hz / 16 A
- (11) Hydraulic unit (optional)

PREPARING SPECIAL TOOL FOR USE

5 First Start-up

The special tool SW42 can optionally be operated:

- using the hydraulic unit SW42 recommended by us,
- using any available hydraulic unit (note the technical data, page 13),
- using the hydraulics system of a tractor (note the technical data, page 13),



The gearbox and the hydraulic unit (if supplied) are both delivered almost ready to use. The galvanised plugs on the gearbox case and hydraulic unit (if supplied) must be replaced with the plastic plugs / the cover before the first start-up.

1. Replace the galvanised plug (1) on the gearbox case with the plug made of plastic (2).

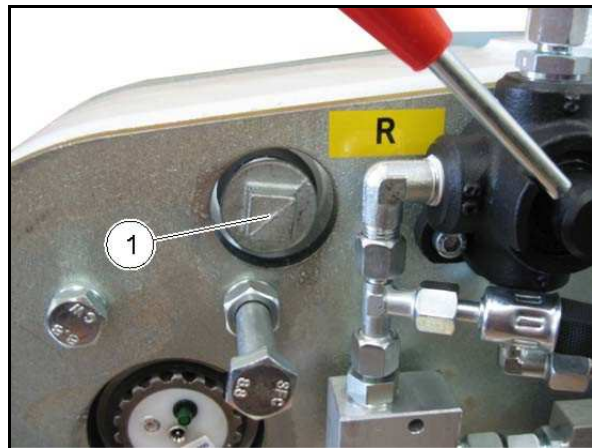

Fig. 12

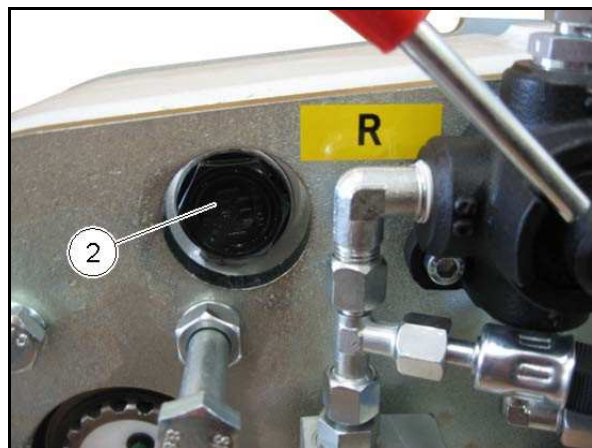

Fig. 13

2. Replace the galvanised plug (3) of the hydraulic oil tank of the hydraulic unit with the plastic cover (4).



Fig. 14

3. Set the base of the gearbox (1) down on a stable work surface.
4. Screw the base on the front and rear side (2) firmly to a worktop.

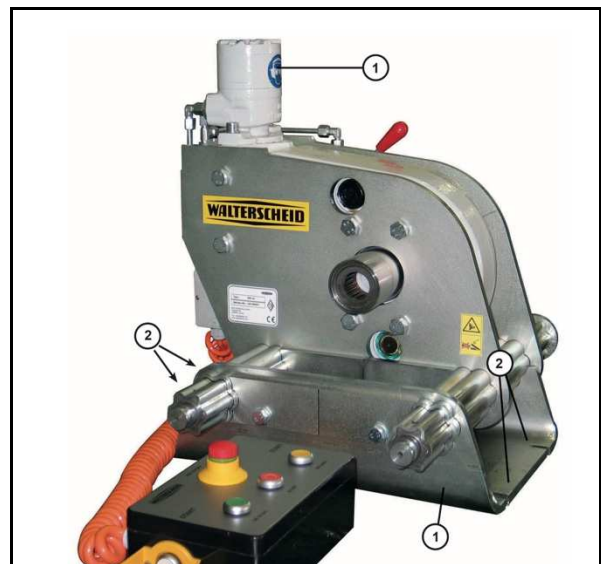

Fig. 15

5.1 Connecting hydraulic hose lines of the gearbox to the connections of the hydraulic drive

1. Connect the hydraulic hose lines (1) and (2) to the connections of a hydraulic unit or to the hydraulics system of a tractor.

Fig. 16 shows the connection of the hydraulic hose lines on the Walterscheid hydraulic unit (3).

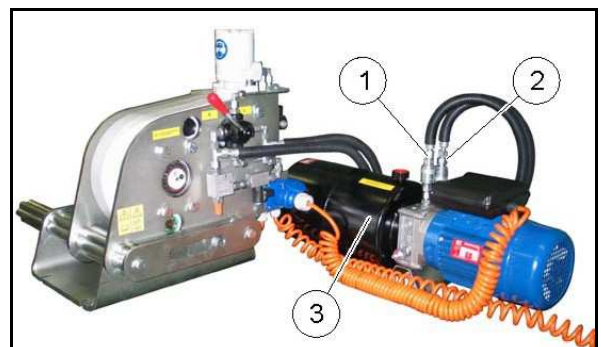

Fig. 16

PREPARING SPECIAL TOOL FOR USE

5.2 Connecting power supply



Ensure that the mains connection cable is not damaged, e.g. due to running over, crushing, dragging or similar. Protect the mains connection cable against heat, oil and sharp edges.

1. Plug the connector (1) of the power supply for the hydraulic unit (if supplied) in the socket of the gearbox unit.
2. Plug the mains connector (2) of the mains connection cable for the gearbox unit into a mains power socket (230 V / 50 Hz).

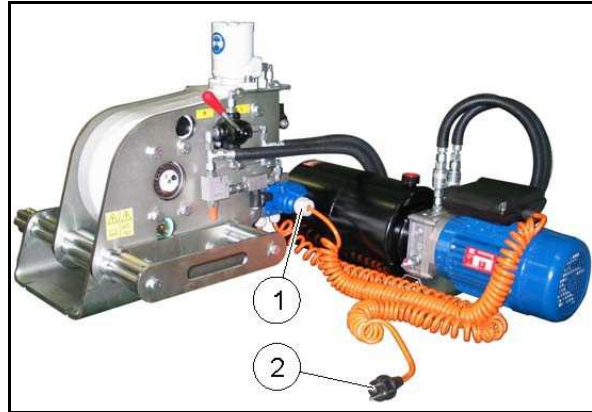

Fig. 17

5.3 Installing "SW42 Analysis2_0" program

The "SW42 Analysis2_0" program is used for recording, analysing and documenting the measured values determined by the measuring hub of the special tool for testing the functionality of overload clutches. Install this program on a computer (PC or laptop).

5.3.1 System requirements

- Operating system:
 - Windows XP
 - Windows Vista
 - Windows 7
 - Windows 10

- Hardware requirements, depending on operating system and software running in parallel:
 - CPU from 1,5 GHz

- RAM:
 - 1 GB
- Graphic resolution at least 800 x 600
- Bluetooth adapter; integrated in the computer or external

5.3.2 Installing the program as follows



You must be logged in as Administrator or member of the Administrators group to install the program.

1. Insert the CD-ROM in a drive.
2. Double click on the "SW42 Analysis2_0.exe" file.
3. Follow the instructions on the screen until the installation is completed.

PREPARING SPECIAL TOOL FOR USE

5.3.3 Setting up computer to receive incoming Bluetooth connections

The measured values determined by the measuring hub of the SW42 special tool are transmitted via Bluetooth connection to the "SW42 Analysis2.0" program on your computer. You must set up your computer to receive incoming Bluetooth connections so that your computer can establish a connection to the measuring hub.

1. Before you can add your computer to the Bluetooth-capable measuring hub, you must do two things so that it is ensured that your computer and the measuring hub can be connected:

- 1.1 Add an external Bluetooth adapter to your computer if your computer does not have its own Bluetooth adapter. Insert the adapter into a USB port for this.
- 1.2 Align the computer with the measuring hub so that the "Bluetooth" radio signal of the measuring hub can be found by the computer.

2. Switch on the measuring hub.

- 2.1 Plug the mains connector of the mains connection cable for the gearbox unit into a mains power socket (220 – 240 V / 50 – 60 Hz).
- 2.2 Switch on the measuring hub using the ON / OFF switch (1).
 - The green LED lamp lights when the measuring hub is switched on.
 - The measuring hub is in search mode and emits a radio signal so that the measuring hub can be detected by the computer.

3. Wait while Windows looks for Bluetooth-capable devices and displays "BAmobile_2".

4. Then click on "BAmobile_2" and follow the instructions on the screen to configure your computer to receive incoming Bluetooth connections.

→ The Bluetooth connection is set up.

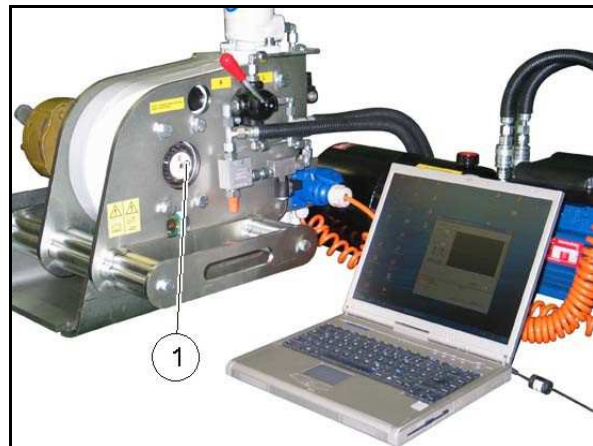

Fig.18

5. Note the serial connection assigned by Windows (COM port), e.g. COM45.

The information about the serial connection can usually be found under:

Control Panel
Hardware and Sound
Bluetooth devices
Right click on
BAmobile_2
Properties
Services

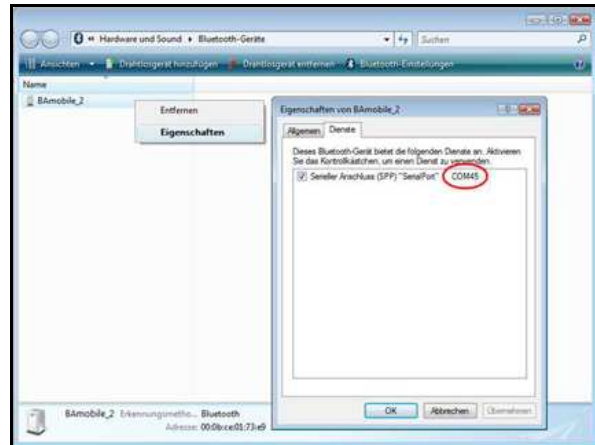

Fig. 19

SETTING UP SPECIAL TOOL

6 Setting up Special Tool

6.1 Inserting / removing profile pins in / from measuring hub



Always select the appropriate profile pin for the profile of the overload clutch to be tested.

Inserting

1. Clean the profile pin (1) if necessary.
2. Insert both halves of the split washer (2) into the groove (3) of the profile pin.

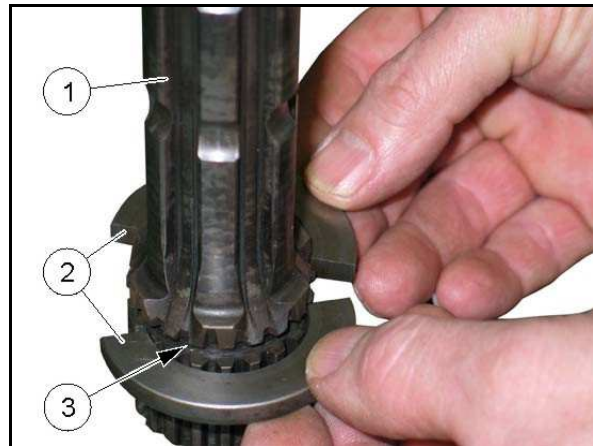

Fig. 20

Fig. 21 shows the profile pin with the inserted two halves of the split washer.



Fig. 21

3. Push the profile pin (1) with the inserted two halves of the split washer into the inner profile $1 \frac{3}{4}$ " (20) of the measuring hub (2).

**Fig. 22**

4. Secure the profile pin in the measuring hub using the circlip (1).

Removal

1. Remove the circlip.
2. Pull the profile pin out of the measuring hub.

**Fig. 23**

SETTING UP SPECIAL TOOL

6.2 Selecting torque support / torque flange mounting



Always select the appropriate torque support / torque flange mounting for the design (with or without yokes / flange yokes) and for the torque to be transferred of the overload clutch to be tested.



The technical data of the overload clutch to be tested can be found on the clutch housing.

Fig. 24 shows **example** marking of an overload clutch:

- (1) Clutch type: K64/22
- (2) Rotation direction: R = clockwise
- (3) Month: 10 (October)
- (4) Year: 09 (2009)
- (5) Order No. 108795
- (6) Sequential No. 4
- (7) Torque (daNm): 200

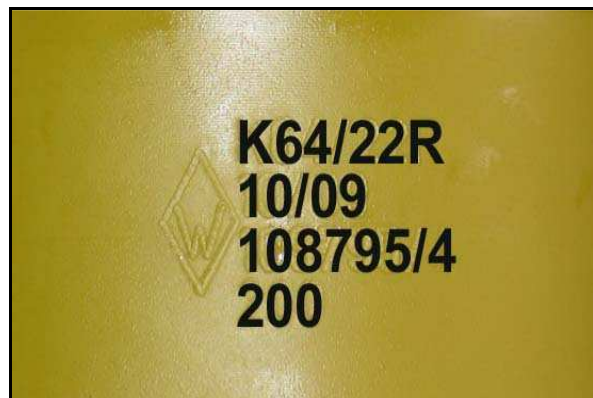

Fig. 24

- (1) Torque support 300 daNm (3,000 Nm)

This torque support is suitable for overload clutches with yokes and a maximum torque M of 300 daNm (3,000 Nm) to be transferred.

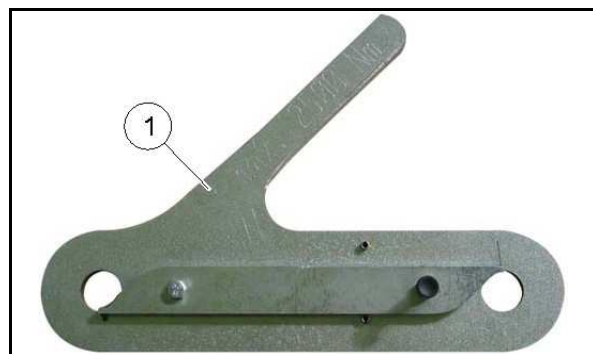

Fig. 25

- (2) Torque support 500 daNm (5,000 Nm)

This torque support is suitable for overload clutches with yokes and a maximum torque M of 500 daNm (5,000 Nm) to be transferred.

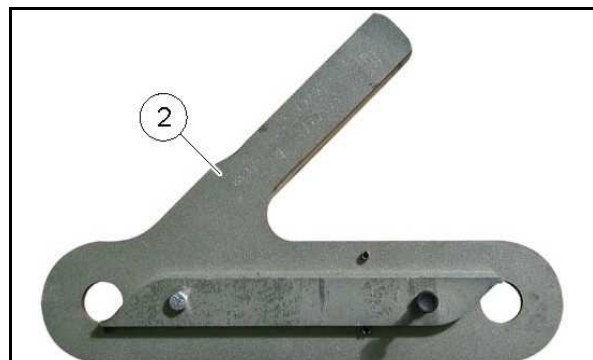

Fig. 26

(3) Torque flange mounting 500 daNm
(5,000 Nm)

This flange mounting is suitable for
(built-in) overload clutches with
mounting flange and a maximum
torque M of 500 daNm (5,000 Nm) to
be transferred.

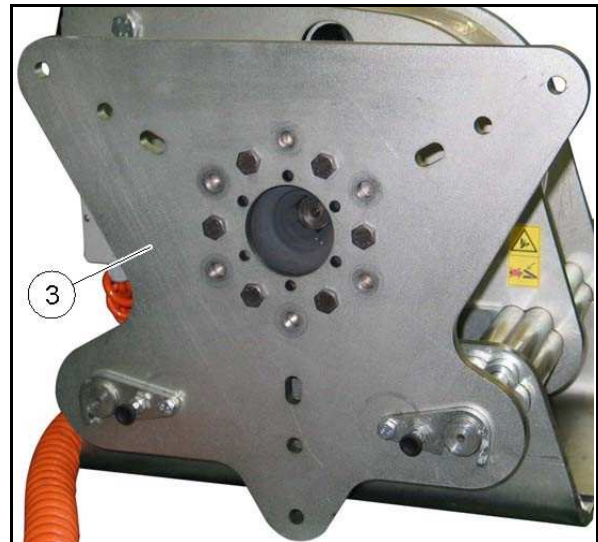



Fig. 27

SETTING UP SPECIAL TOOL

6.3 Operating special tool using two-hand control

The special tool is operated using the various buttons of the two-hand control (1).

- (1) Two-hand control.
- (2) START / ON button. The tester is driven by pressing and holding the two buttons (2) simultaneously. The drive of the tester stops as soon as you release any of the two buttons.
- (3) Button  min. 10 sec. If this button (3) is also pressed for 10 seconds while simultaneously pressing and holding the two buttons (2), the tester is driven in continuous operation.
- (4) STOP button. The continuous operation of the tester stops as soon as you press this button.
- (5) 300 - 500 daNm button. Also press this button (5) while simultaneously pressing and holding the two buttons (2) if the torque to be transferred of the overload clutch to be tested is more than 300 daNm.
- (6) NOT-HALT / EMERGENCY STOP button. Press this button (6) in the event of hazards arising for persons or damage to the tester. The drive of the tester stops immediately.

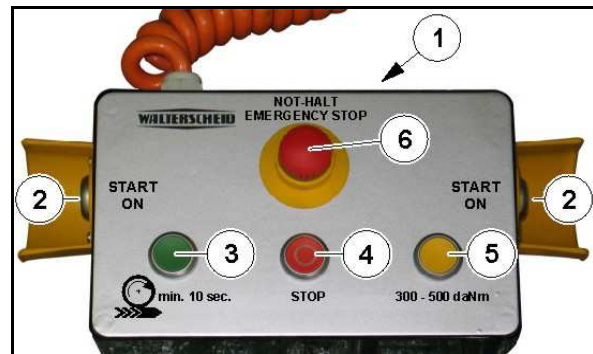

Fig. 28

7 Attaching Overload Clutch on Profile Pin and Securing

Securing the overload clutch against twisting depends on whether the overload clutch to be tested is equipped with or without yoke.



Refer to the marking on the clutch housing of the overload clutch to be tested for the following information:

- the torque to be transferred of the overload clutch,
- the rotation direction of the overload clutch (R = clockwise and L = anticlockwise). The rotation direction is always clockwise if no R or L marking is present.

7.1 Overload clutch with yoke

1. Insert the required profile pin in the measuring hub. See also the chapter "Inserting profile pin in measuring hub / Removing profile pin from measuring hub" starting on page 42.
 2. Read off the torque to be transferred of the overload clutch to be tested on the clutch housing, e.g. 200 daNm.
 3. Select the required torque support in accordance with the torque value read on the housing. See also the chapter "Selecting torque support / torque flange mounting" starting on page 44.
 4. Push the overload clutch on to the profile pin until the latch engages in the ring groove or the clutch is fixed using the axial securing screw connection.
- The overload clutch is secured against axial displacement on the measuring hub.

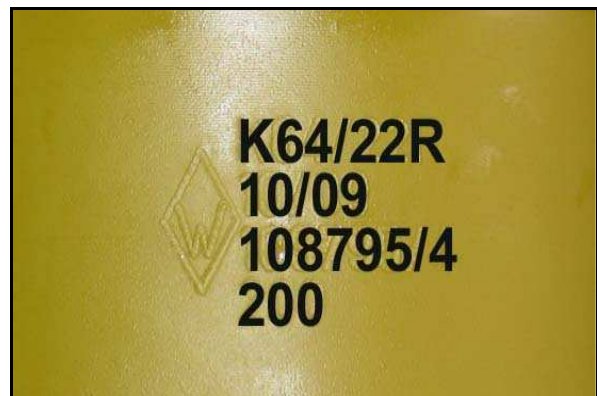

Fig. 29



Fig. 30

ATTACHING OVERLOAD CLUTCH ON PROFILE PIN AND SECURING

5. Secure the overload clutch against twisting using the torque support.
 - 5.1 Push the torque support onto both pins of the carriage.
 - 5.2 Secure the torque support using the locking in the ring groove of the respective pin.
 - 5.3 Check whether the locking is correctly engaged on the pin. The locking is correctly engaged if you cannot pull the torque support off the pin.
 - 5.4 Insert the torque support between the yoke legs of the clutch.
 - 5.5 Check the rotation direction of the overload clutch (R = clockwise and L = anticlockwise).



Fig. 31

7.2 Overload clutch without yoke

1. Insert the required profile pin in the measuring hub. See also the chapter "Inserting profile pin in measuring hub / Removing profile pin from measuring hub" starting on page 42.
2. Push the overload clutch on to the profile pin until the latch engages in the ring groove or the clutch is fixed using the axial securing screw connection.

→ The overload clutch is secured against axial displacement on the measuring hub.

3. Secure the overload clutch against twisting using the torque flange mounting.
 - 3.1 Push the torque flange mounting (1) onto both pins (2) of the carriage.
 - 3.2 Secure the torque flange mounting using two latches (3) in the ring groove of the respective pin.
 - 3.3 Check whether the locking (3) is correctly engaged on the pin (2). The locking is correctly engaged if you cannot pull the torque flange mounting off the pin.

4. Align the overload clutch opposite the torque flange mounting.
5. Bolt the overload clutch to the torque flange mounting.
6. Tighten all required bolts (4).

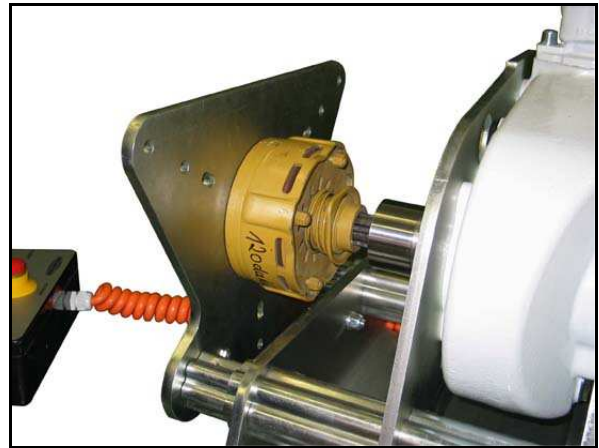

Fig. 32

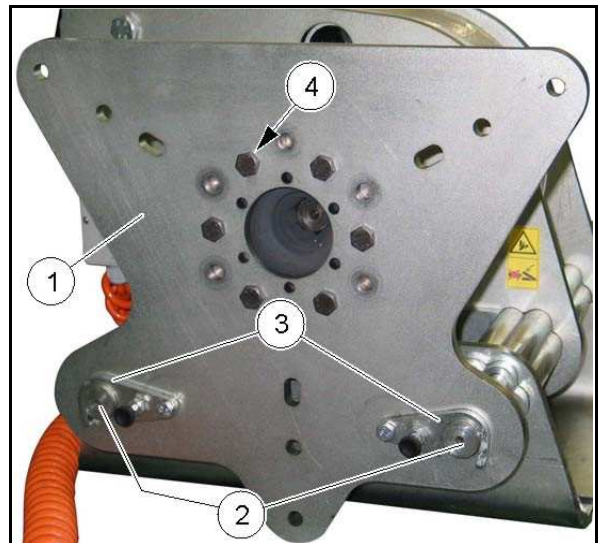

Fig. 33

TESTING FUNCTIONALITY OF OVERLOAD CLUTCHES

8 Testing Functionality of Overload Clutches

The special tool SW42 determines the actually transferred torque of the overload clutch for testing the functionality of overload clutches. The measured values of the measuring hub determined here are transferred via a Bluetooth connection to the "SW42 Analysis2_0" program started on the computer and recorded.

The recorded measured values are automatically analysed, transferred to a measurement report and shown as a diagram. This analysis also provides an assessment of the condition of the overload clutch. After completion of the test, the recorded measured values and the analysis can be saved as a PDF file.

DANGER



Hazards from drawing in by rotating parts!

These hazards can cause severe injuries including death.

- Wear close-fitting clothing. Do not wear any clothing – no scarf, tie, jewellery – which could get trapped in the rotating parts.
- Tie back long hair. Secure long hair, e.g. with a headscarf, a cap, a helmet etc.
- Never leave the tester unsupervised when continuous operation is selected.



Wear hearing protection when testing shifting clutches in continuous operation.



Overload clutches with a maximum torque of 500 daNm can be tested.

In normal operation, the torque of an overload clutch with maximum 300 daNm is tested. You must also press the "300 - 500 daNm" button if the torque of the overload clutch to be checked is more than 300 daNm.

8.1 Testing friction clutches



The test speed is approx. 2.5 rpm.



- **Always let friction clutches cool down to room temperature before testing them.** This must be done irrespective of whether the friction clutch comes directly from being in use or whether it is still heated from a running-in process. A friction clutch only transfers its operation torque at room temperature.
- **Observe the following when testing friction clutches:**
 - **Friction clutches coming from being in use** must be vented even after short idle time before the torque measurement. Observe the operating manual of the PTO drive shaft for the ventilation of the friction clutch. Download the corresponding operating manual from our website if necessary.

www.walterscheid.com/en/downloads/manuals/
 - **If individual components** such as friction disks and/or drive plates have been replaced or the complete friction clutch has been **replaced** from individual parts, the friction clutches must undergo a running-in process before the torque measurement. Ensure that the friction clutch does not overheat during the running-in process.

TESTING FUNCTIONALITY OF OVERLOAD CLUTCHES

8.2 Testing radial pin and cam-type cut-out clutches



The test speed is approx. 2.5 rpm.



- **Observe the following when testing radial pin clutches and cam-type cut-out clutches:**
 - o Clutches taken from stock or coming from being in use can be tested directly.
 - o **If individual components** such as cams, springs or spring pack assemblies, case have been replaced or the complete respective clutch has been **replaced** from individual parts, a running-in process for these clutches will be required before the torque measurement. Let the overload clutch run forward or run in for at least 30 seconds.

8.3 Measuring torque on a friction clutch, radial pin clutch or cam-type cut-out clutch

8.3.1 Switching on measuring hub

1. Plug the mains connector of the mains connection cable for the gearbox unit into a mains power socket (220 – 240 V / 50 – 60 Hz).
 2. Switch on the measuring hub using the ON / OFF switch (1).
- The green LED lamp lights when the measuring hub is switched on.

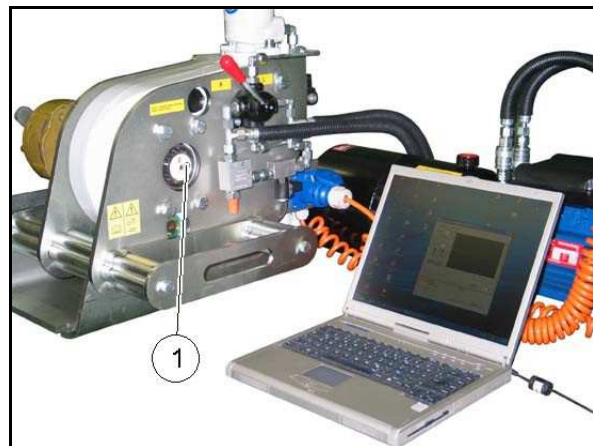

Fig. 34

8.3.2 Starting the "SW42 Analysis2_0" program

3. Start the "SW42 Analysis2_0" program via the Start menu (Fig. 35).

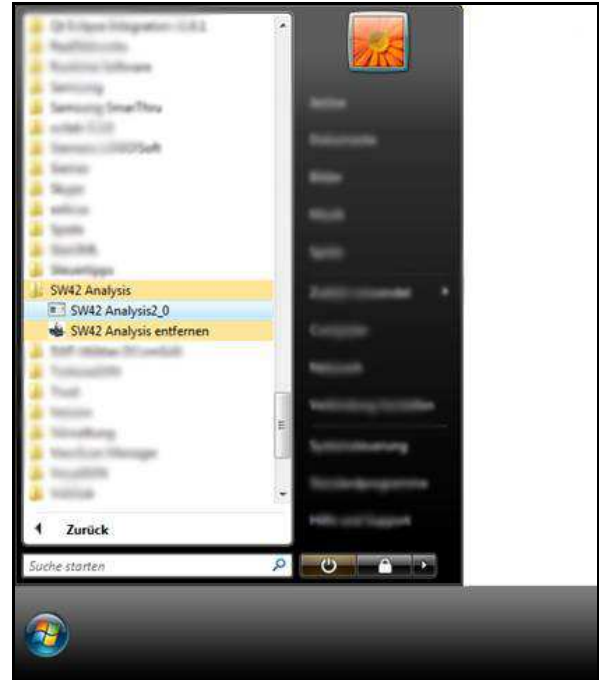

Fig. 35

8.3.3 Selecting language and inputting company details



The "Dealer Information" window opens the first time you start the "SW42 Analysis2_0" program. You must select the required language and enter your company details in this window once.

- 3.1 Select the required language in the "Language" selection field.
- 3.2 Enter your company details in the provided fields. This information is displayed later on the measurement reports.
- 3.3 Confirm the language selection and the entries with "OK".

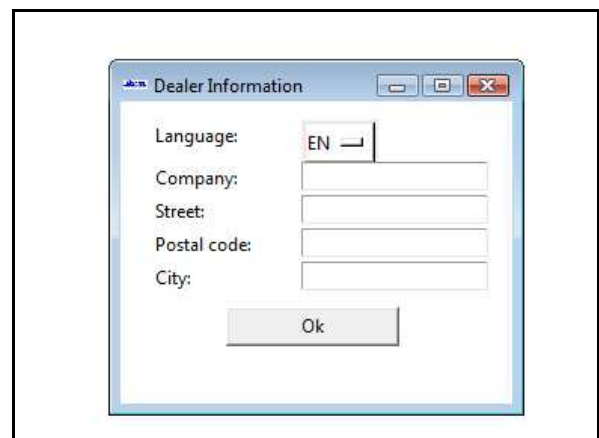

Fig. 36

TESTING FUNCTIONALITY OF OVERLOAD CLUTCHES

8.3.4 Selecting COM connection for receiving incoming Bluetooth connections



You must now establish the Bluetooth connection between the measuring hub and your computer if the port has been otherwise used in the meantime or if you use a different computer.

4. Establish the Bluetooth connection between the measuring hub and your computer.
 - 4.1 In the "Measuring hub" window, select the serial connection (COM connection) for the Bluetooth connection assigned by Windows when setting up the Bluetooth connection. See also the chapter "Setting up computer to receive incoming Bluetooth connections", starting on page 40.
5. Click on the "Start measurement" button.

→ The "Customer information" window opens.

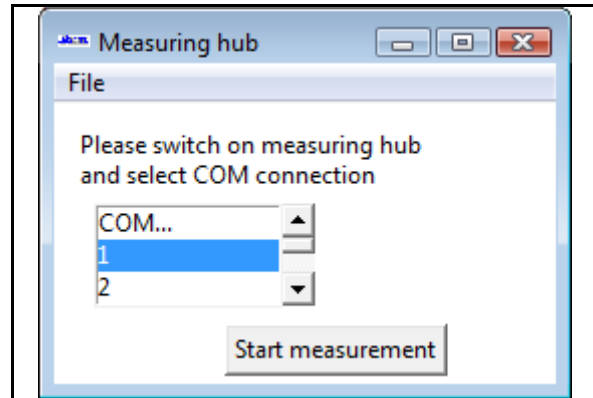

Fig. 37

8.3.5 Entering and/or selecting customer, implement and clutch details



The "Name", "Overload clutch version" and "Nominal value" fields are mandatory fields and are marked with "*". The required data must strictly be entered and/or selected in these fields.

Fig. 38

6. Input the customer information.
7. Input the details for the implement on which the clutch to be tested will be used.
8. Input the overload clutch type.
9. Select the overload clutch version.
10. Remove the nominal value for the required torque and the rotation direction of the overload clutch from the clutch case of the overload clutch to be tested. See also the chapter "Selecting torque support / torque flange mounting", starting on page 44.
11. Select the nominal value for the required torque by moving the nominal value marking (Fig. 38/1). The numbers above the marking indicate the selected nominal value in daNm.

TESTING FUNCTIONALITY OF OVERLOAD CLUTCHES

8.3.6 Conducting a zero point adjustment of the measuring hub

12. Conduct a zero point adjustment of the measuring hub as follows if the indicated measured value (Fig. 38/2) is not nearly 0 daNm. The charger must not be connected during zero point adjustment.

12.1 Unload the measuring hub completely. The measuring hub is completely unloaded when no overload clutch is attached to the profile pin.

12.2 Click on "Zero point adjustment".

→ The "zero point adjustment" is performed. The displayed measured value (Fig. 38/2) is now almost 0 daNm.

8.3.7 Attaching overload clutch on profile pin and securing

13. Attach the overload clutch to the profile pin. See also the chapter "Attaching overload clutch on profile pin and securing", starting on page 47.

8.3.8 Starting special tool SW42 for the measurement and performing measurement

14. Click on the "Start measurement" button.

→ The "Start SW42" window opens. The "SW42 Analysis2_0" program is operational.

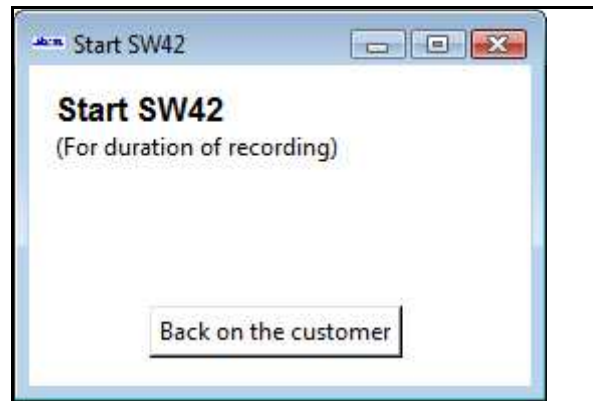

Fig. 39

15. Set the required rotation direction for the overload clutch at the changeover valve (1).
(R = clockwise and L = anticlockwise)



Check the rotation direction at the profile pin. See also the chapter "Attaching overload clutch on profile pin and securing", page 48 (Fig. 31).

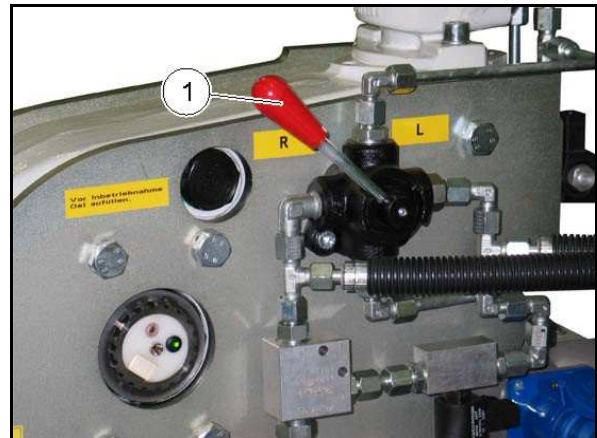



Fig. 40

16. Start the tester.
- 16.1 **Press and hold** the two START / ON (1) buttons simultaneously.
→ The tester starts. The drive stops as soon as you release any of the two buttons.
- 16.2 If you want to drive the tester in continuous operation, press the button  (2) for at least 10 seconds in addition to the two START / ON buttons.
→ The tester runs in continuous operation.

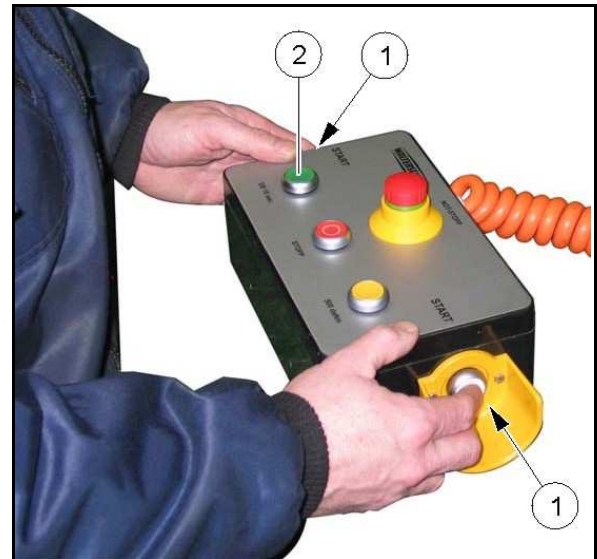

Fig. 41

TESTING FUNCTIONALITY OF OVERLOAD CLUTCHES

8.3.9 Measured data – recording and analysis

After a few seconds, the "Analysis" window opens where the recording and analysis of the measured data are performed automatically.

Warm-up time

The program is in the "warm-up time" mode while the graph shows red during the recording. These measured data are **NOT** taken into account for the analysis.

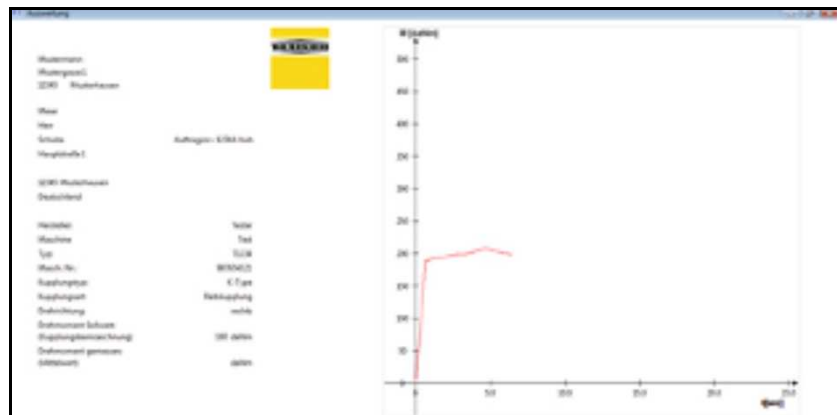

Fig. 42

Recording the measured data

After approx. **25 sec**, the recording of the measured values for the actual transferred torque of the overload clutch starts with the green graph. "**Green**" equals recording. The two blue lines mark the permitted tolerance range for the torque of the overload clutch to be measured.

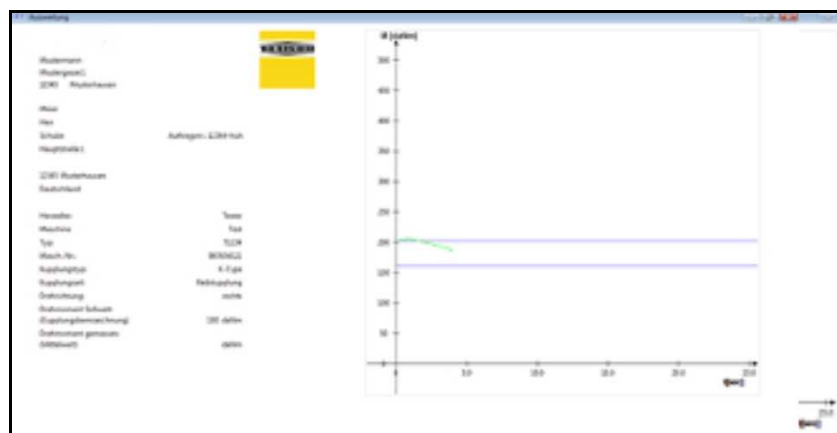

Fig. 43

TESTING FUNCTIONALITY OF OVERLOAD CLUTCHES

8.3.11 Saving measurement report as PDF file

Save the measurement report as a PDF file.

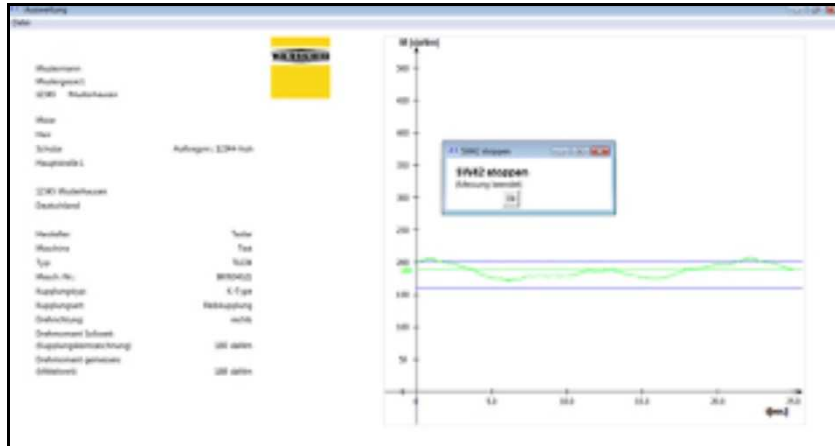

Fig. 46

18. Click on the **File** tab
19. Click on **Save for print**.
20. Click in the **Save** list on the directory or the drive in which you would like to save the PDF file.
21. Click on **Save**.
→ The measurement report is saved as a PDF file.

9 Errors While Testing the Functionality of an Overload Clutch

The following errors can occur before or after starting the torque measurement:

- Bluetooth connection is not established.
- The Bluetooth connection is lost during the measurement.
- Nominal value for the required torque is not reached.
- The "SW42 Analysis2_0" program terminates.

9.1 Bluetooth connection is not established

If the "Measuring hub" window opens repeatedly for the selection of the serial connection (COM connection) for the Bluetooth connection, no Bluetooth communication between the measuring hub and your computer can be established.

1. Delete the "BAmobile_2" Bluetooth connection from your computer.
2. Set up the "BAmobile_2" Bluetooth connection again on your computer. See also the chapter "Setting up computer for receiving incoming Bluetooth connections" starting on page 40.

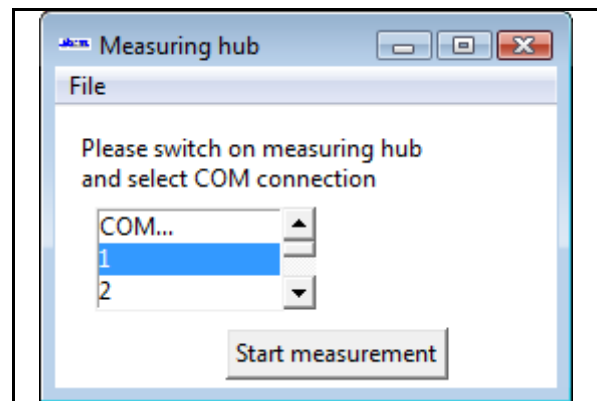

Fig. 47

ERRORS WHILE TESTING THE FUNCTIONALITY OF AN OVERLOAD CLUTCH

9.2 Bluetooth connection is lost during the measurement

If the "Lost Signal" window is displayed during the measurement of an overload clutch, the Bluetooth connection between the measuring hub and your computer has dropped.

The causes for this notification can be:

- the measuring hub has been switched off.
Remedy: Switch on the measuring hub.
- the battery of the measuring hub is discharged.
Remedy: charge the battery.
- the measuring hub signal is not found by the computer, for example because the signal distance is too large.
Remedy: align the computer with the measuring hub so that the signal of the measuring hub can be found by the computer.



Fig. 48

9.3 Nominal value for the required torque is not reached

If the "Start SW42" window on the right opens a short time after starting the measurement, 50% of the nominal value for the required torque for the overload clutch to be tested is not reached.

1. Start the special tool SW42 if necessary. See also the chapter "Starting tester for the measurement and performing measurement" starting on page 56.
2. Click on "Back to the customer" and check and if necessary correct the specified nominal value for the required torque of the overload clutch to be checked. See also the chapter "Entering and/or selecting customer, implement and clutch data" starting on page 55.

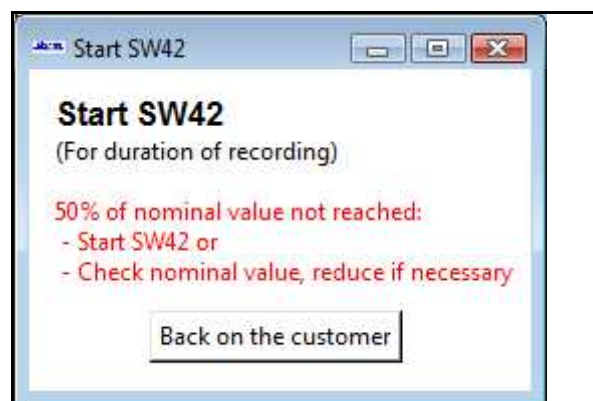

Fig. 49

9.4 The "SW42 Analysis2_0" program ends suddenly

If the program ends suddenly and the error message on the right is displayed, a log file with the required information for localisation of the error cause is created automatically.

1. Please send this log file with a description of the error by E-mail to: **as@kw-siemer.de**
 - 1.1 Open the directory "C:\SW42 Analysis2_0" on your computer.
 - 1.2 Make a copy of the log file "Index.exe.log".
 - 1.3 Attach this log file to the E-mail.

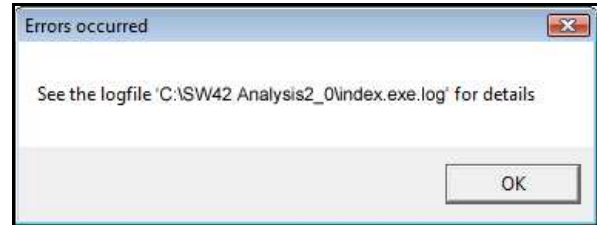

Fig. 50

CLEANING, MAINTENANCE AND REPAIRS

10 Cleaning, Maintenance and Repairs



Also note the instructions in the following chapters for cleaning, maintenance and repair:

- "Obligations of the operator" on page 17,
- "Qualification of the persons" on page 18,
- "Basic safety instructions" starting on page 22,
- "Warning signs and instruction signs" starting on page 27.

Observance of these chapters provides your safety.

10.1 Removing and installing measuring hub

You must remove the measuring hub:

- once per year for the calibration,
- for replacement of the battery.

10.1.1 Removing measuring hub

1. Unplug the mains connector of the mains connection cable from the power socket.
2. Remove the circlip (1) of the profile pin.
3. Pull the profile pin out of the measuring hub.



Fig. 51

4. Remove the circlip of the measuring hub.



Fig. 52

5. Remove the shims from the gearbox case.



Fig. 53

6. Pull the measuring hub out of the hollow shaft.

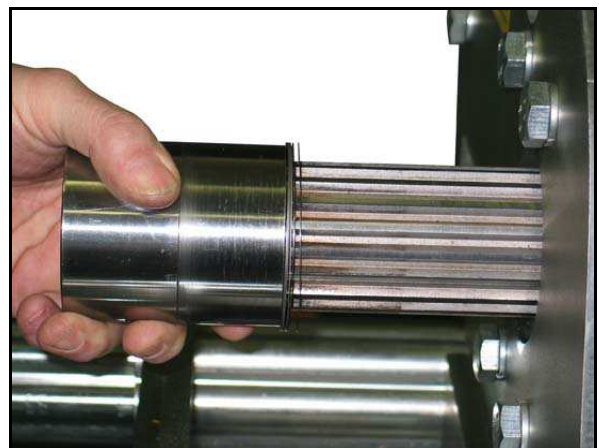

Fig. 54

CLEANING, MAINTENANCE AND REPAIRS

7. Remove the shims from the measuring hub.
8. Keep all shims and circlips safely when you send the measuring hub to the manufacturer for calibration.
9. Send the measuring hub for calibration carefully packaged to the manufacturer.

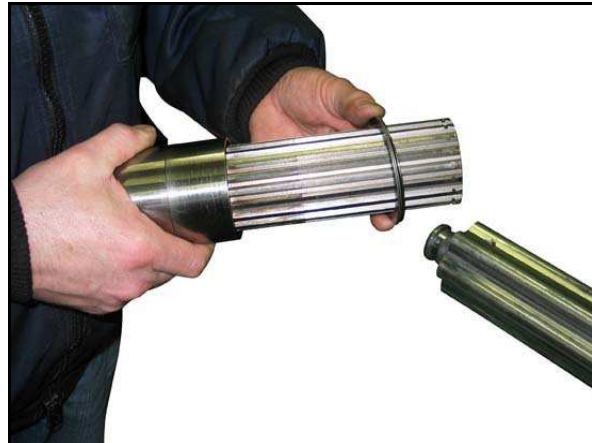

Fig. 55

10.1.2 Installing measuring hub

1. Put the shims on the measuring hub.



Fig. 56

2. Push the measuring hub into the hollow shaft.

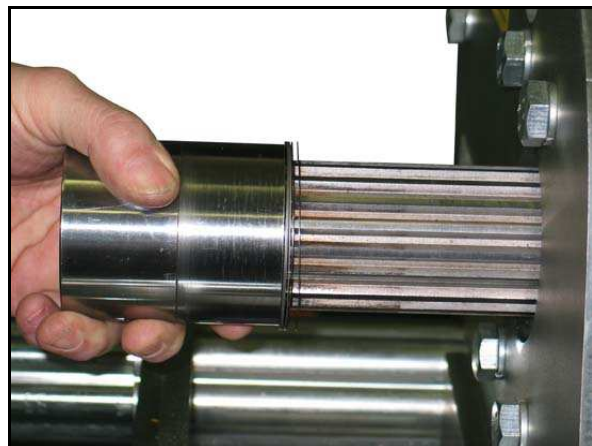

Fig. 57

3. Put the shims on the measuring hub.



Fig. 58

4. Secure the measuring hub in the hollow shaft using the circlip.



Fig. 59

CLEANING, MAINTENANCE AND REPAIRS

10.2 Charging battery of the measuring hub

You must charge the battery if the red LED lamp (1) lights.

1. Switch off the measuring hub using the ON / OFF switch (2).
- The green LED lamp does not light when the measuring hub is switched off.

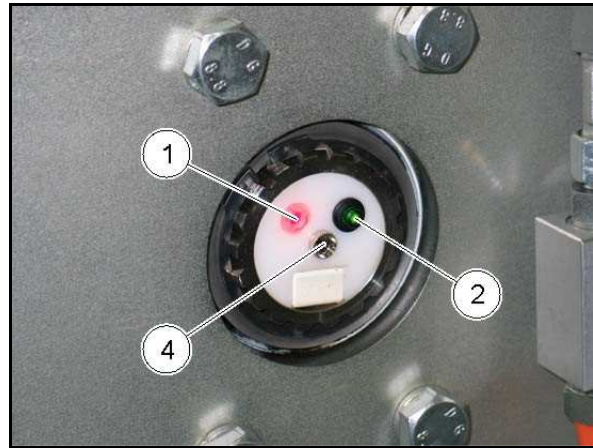

Fig. 60

2. Plug the DC connector (3) of the charger into the DC input (4) of the measuring hub.
 3. Plug the mains connector (5) of the charger into a mains power socket (220 – 240 V / 50 60 Hz).
- The indicator lamp (6) of the charger flashes orange while the battery is charging. If the indicator lamp lights orange without flashing, the battery is approx. 80-95% charged. This charge status is sufficient for operation of the measuring hub. The battery is completely charged if the indicator lamp lights green.
4. Unplug the mains connector of the charger from the power socket.
 5. Unplug the DC connector of the charger from the DC input of the measuring hub.

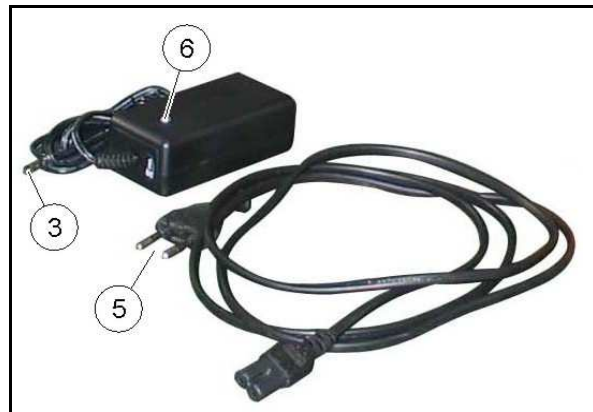

Fig. 61

10.3 Replacing battery of the measuring hub

You must replace the battery if the operating time of the battery drops significantly even when completely charged.

1. Switch off the measuring hub using the ON / OFF switch (1).
- The green LED lamp does not light when the measuring hub is switched off.

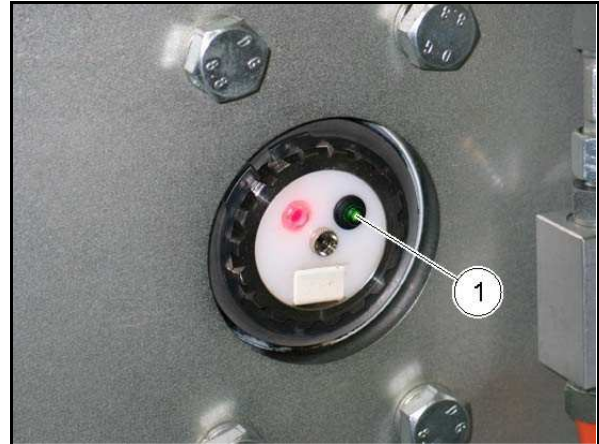

Fig. 62

2. Unplug the mains connector of the mains connection cable of the tester from the power socket.
3. Remove the measuring hub. See also the chapter "Removing measuring hub" starting on page 64.
4. Remove the cap of the battery case using a screwdriver (Fig. 63).



Fig. 63

5. Remove the battery from the battery case (Fig. 64).
6. Detach the connector.
7. Replace the battery.
8. Insert the battery into the battery case.
9. Screw the cap onto the battery case.
10. Reinstall the measuring hub. See also the chapter "Installing measuring hub" starting on page 66.
11. Used batteries are not to be disposed in household waste. The batteries must be handed over to a collection point for old batteries.

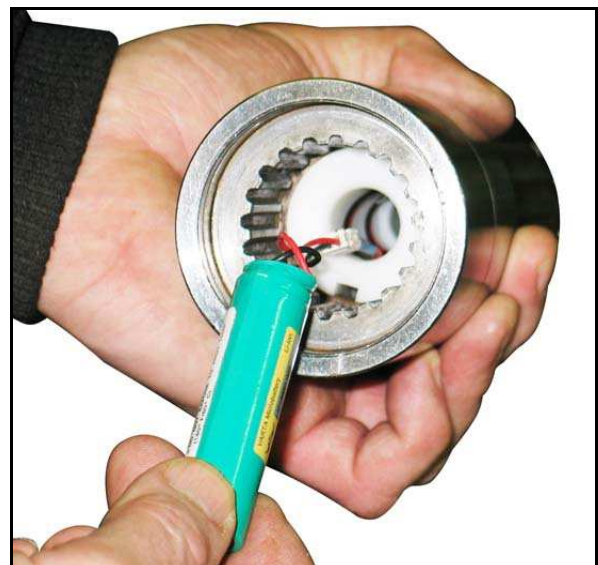

Fig. 64

CLEANING, MAINTENANCE AND REPAIRS

10.4 Checking oil level



- Check the oil in the tester and in the hydraulic unit (if supplied) before the first start-up.
 - Gearbox: gearbox oil SAE 90 GL-4, fill quantity 4.5 litres.
 - Hydraulic unit: hydraulic oil HLP 46, fill quantity 8 litres.

1. Pay attention to sufficient oil level in the gearbox.



Fig. 65

2. Pay attention to sufficient oil level in the tank of the hydraulic unit.



Fig. 66

EC DECLARATION OF CONFORMITY

11 EC Declaration of Conformity

EC Declaration of Conformity

for the purpose of the EC Machinery Directive 2006/42/EC, Appendix II, 1.A

Manufacturer:

WALTERSCHEID GmbH
Hauptstraße 150
D-53797 Lohmar

Person domiciled in the European Union who is authorised to compile the relevant technical documents:

WALTERSCHEID GmbH
Hauptstraße 150
D-53797 Lohmar

Description and identification of the machine:

Designation: **WALTERSCHEID special tool for checking the functionality of overload clutches during repair, reassembly or adjustment**

Type: **SW42**

Serial number:

Trade name: **Special Tool SW42**

It is expressly declared that the machine complies with all relevant provisions of the following EC Directives:

Directive 2006/42/EC Directive 2006/42/EC of May 17, 2006

References of the applied harmonised standards in accordance with Article 7 Paragraph 2:

EN ISO 12100:2010 Safety of machines – General design principles – Risk assessment and risk reduction (ISO 12100:2010)

EN ISO 4413:2010 Fluid technology – General rules and technical safety requirements for hydraulic systems and their components (ISO 4413:2010)

EN 574:1996 + A1:2008 Safety of machines – two-hand control – functional aspects - design principles

Lohmar, June 2014
Place, date

Signature
Norbert Fartmann
Customer Service Manager

SPARE PARTS LIST

12 Spare Parts List

12.1 Frame

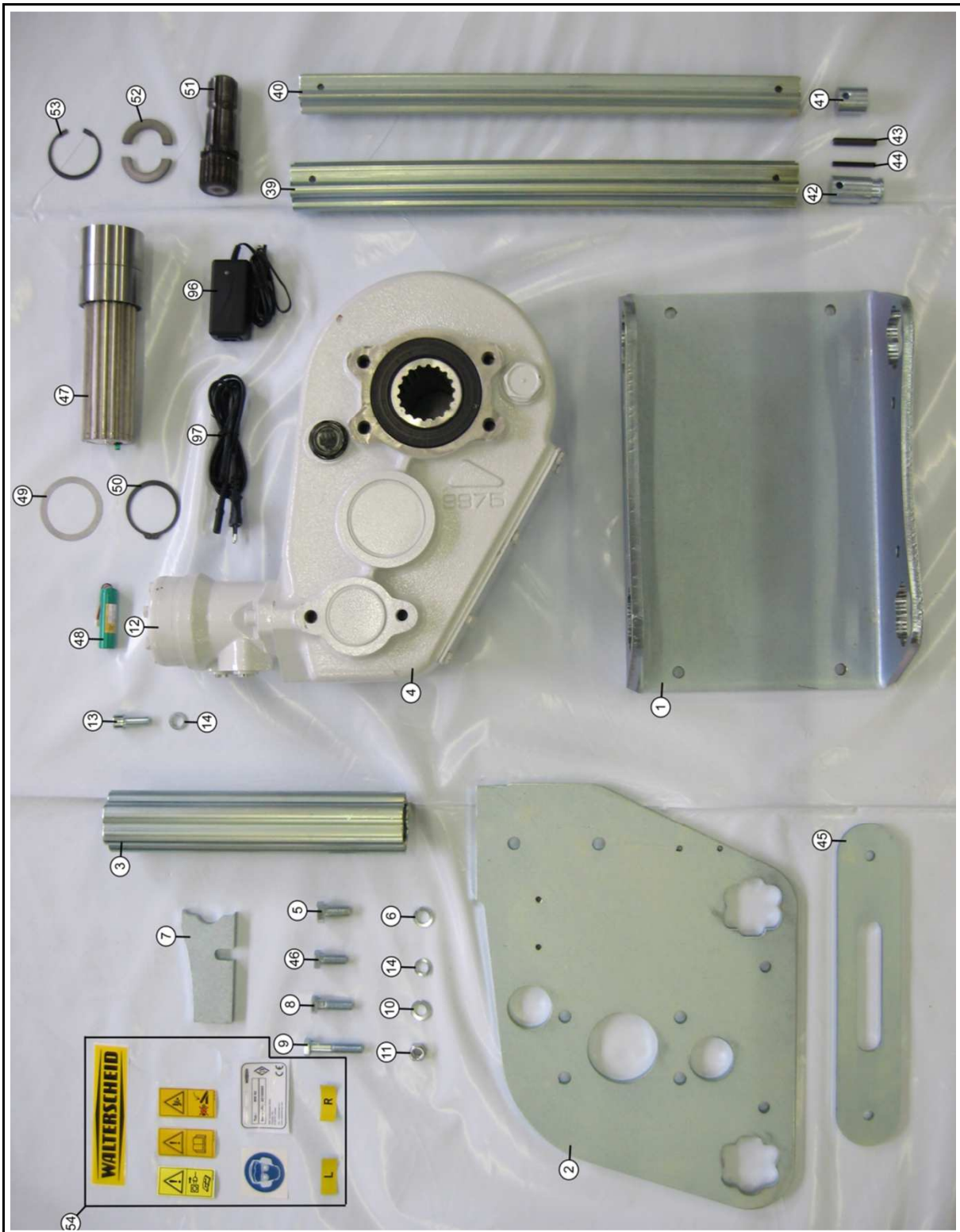

Fig. 67

12.2 Counter bearing



Fig. 68

SPARE PARTS LIST

12.3 Hydraulics

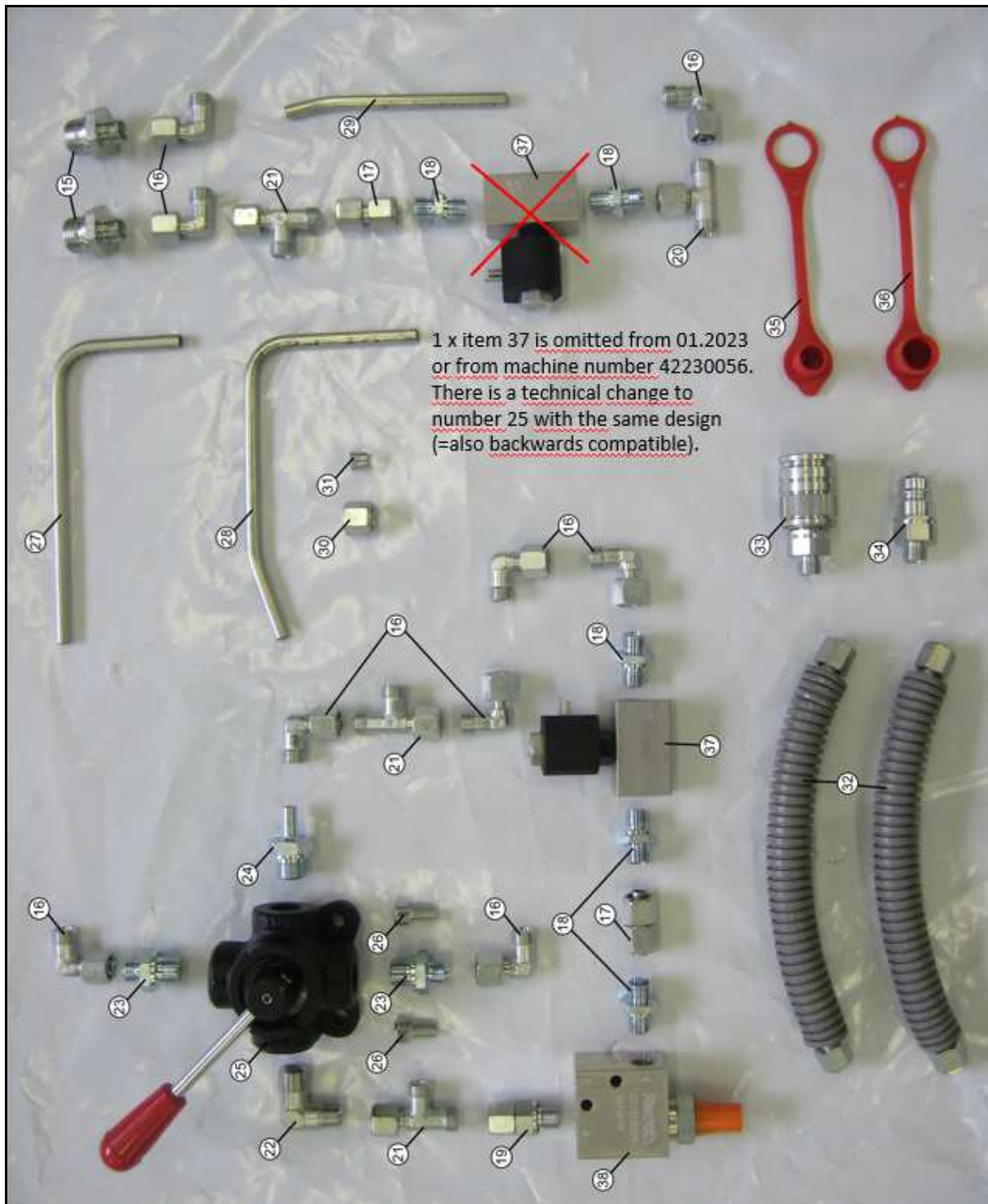

Fig. 69

12.4 Hydraulic unit SW42



Fig. 70

SPARE PARTS LIST

12.5 Controller

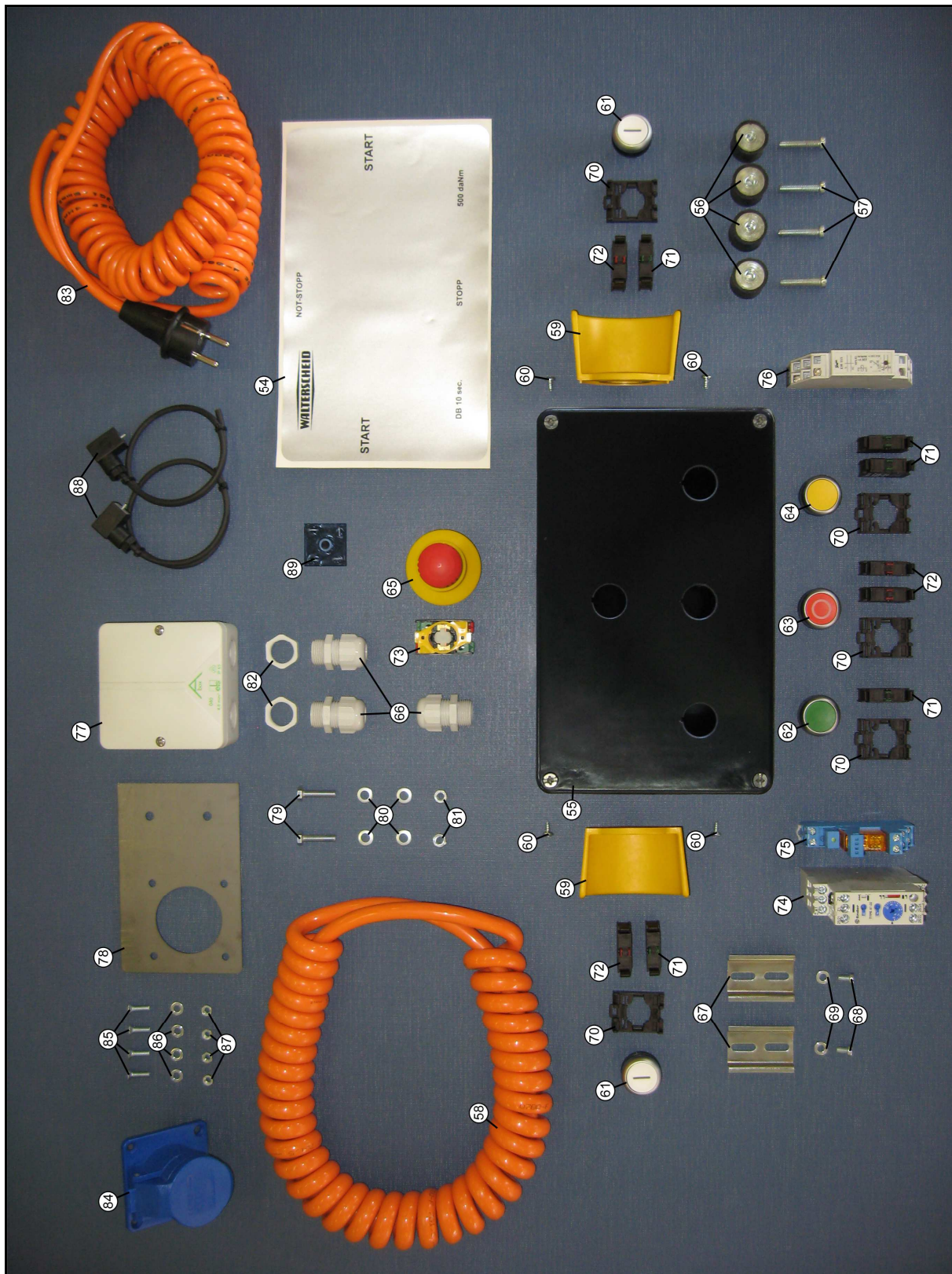

Fig. 71

12.6 Parts list

Pos.	Drawing No.	Designation	Dimensions	Standard	Quantity [Pieces]	up to / from serial number
1	SW42-001	Base			1	
2	SW42-002	Flange plate			2	
3	SW42-003	Profile tube S6	l=335		2	
4	SW42-004	Gearbox RT350	RT 350		1	
5	SW42-005	Bolt	14x30 blue	DIN 933	12	
6	SW42-006	Spring washer	14 mm blue	DIN 127B	12	
7	SW42-007	Clamping piece			6	
8	SW42-008	Bolt	12x40 blue	DIN 933	4	
9	SW42-009	Bolt	14x60 blue	DIN 931	2	
10	SW42-010	Washer	12 mm blue	DIN 125A	12	
11	SW42-011	Nut, self-locking	M12 blue	DIN 985	6	
12	SW42-012	Oil motor	80 cm ³		1	
13	SW42-013	Bolt	12x30 blue	DIN 912	2	
14	SW42-014	Spring washer	12 mm blue	DIN 127B	4	
15	SW42-015	Screw-in coupling	8L R12 blue		2	
16	SW42-016	Elbow	8L MG blue		9	
17	SW42-017	Connector	8L blue		2	
18	SW42-018	Screw-in coupling	8L R14 blue		5	
19	SW42-019	Screw-in coupling	8L R14 blue		3	
20	SW42-020	T piece	8L GMG blue		1	
21	SW42-021	T piece	8L MGG blue		3	
22	SW42-022	Angle screw-in connection	8L R3/8 blue		1	
23	SW42-023	Screw-in coupling	8L R3/8 blue		2	
24	SW42-024	Screw-in coupling	8L R3/8		1	
25	SW42-025	4/2-way valve	R3/8 brown.		1	
26	SW42-026	Bolt	8x16 blue	DIN 912	2	
27	SW42-027	Hydraulic tube 230	8x1 l=230		1	
28	SW42-028	Hydraulic tube 255	8x1 l=255		1	
29	SW42-029	Hydraulic tube 127	8x1 l=127		1	
30	SW42-030	Union nut	8L blue		9	
31	SW42-031	Cutting ring	8L		9	
32	SW42-032	Hydraulic hose, assembled	8L l=1,500		2	
33	SW42-033	Standard coupling	8L BG2		2	
34	SW42-034	Standard connector	8L BG2		2	
35	SW42-035	Dust plug	BG2		2	
36	SW42-036	Dust cap	BG2		2	
37	SW42-037	2/2-way valve MHW-C-080F			2	until 42210055
37	SW42-037	2/2-way valve MHW-C-080F			1	from 42230056
38	SW42-038	DBV VSBN-08A-10	100 bar		1	
39	SW42-039	Profile tube S5	l=550		1	
40	SW42-040	Profile tube S4	l=550		1	

SPARE PARTS LIST

Pos.	Drawing No.	Designation	Dimensions	Standard	Quantity [Pieces]	up to / from serial number
41	SW42-041	Threaded pin			1	
42	SW42-042	Locating pin			1	
43	SW42-043	Clamping pin	8x50	DIN 1481	4	
44	SW42-044	Clamping pin	5x50	DIN 1481	4	
45	SW42-045	End stop			1	
46	SW42-046	Bolt	12x30 blue		2	
47	SW42-047.1	Measuring hub, assembled			1	from 42110011
48	SW42-048	Battery, Li-Ion	4.2V, 2200 mAh		1	
49	SW42-049	Shim ring	60x75x0.2		n.B.	
50	SW42-050	Circlip, outer	60	DIN 471	1	
51	SW42-051	Profile shaft, see from Pos. 201			1	
52	SW42-052	Retaining washer, see Pos. 200			1	
53	SW42-053	Circlip, inner	60x2	DIN 472	1	
54	SW42-054	Sticker set			1	
55	SW42-055	Case machined			1	
56	SW42-056	Rubber damper	20x15x6		4	
57	SW42-057	Bolt	M6x25 blue	DIN 84	4	
58	SW42-058	Spiral cable	7 x 1.5 mm ²		1	
59	SW42-059	Protective collar	M22-XG-PV		2	
60	SW42-060	Self-tapping screw	4.2x9.5 blue	DIN 7981C	4	
61	SW42-061	Push button, white with 1	M22-D-W-X1		2	
62	SW42-062	Push button, green	M22-D-G		1	
63	SW42-063	Push button, red with 0	M22-D-R-X0		1	
64	SW42-064	Push button, yellow	M22-D-Y		1	
65	SW42-065	EMERGENCY STOP button			1	
66	SW42-066	Cable gland	M20 x 1.5		3	
67	SW42-067	DIN rail	35x7.5 l=45		2	
68	SW42-068	Bolt	M5x8 blue	DIN 84	2	
69	SW42-069	U-washer	M5 blue	DIN 125A	2	
70	SW42-070	Adapter plate	M22-A		5	
71	SW42-071	Normally open contact	M22-K10		5	
72	SW42-072	Normally closed contact	M22-K01		4	
73	SW42-073	Module, Emergency Stop			1	
74	SW42-074	Multifunction relay			1	
75	SW42-075	Coupling relay			1	
76	SW42-076	Safety relay	SNZ 4052 K		1	
77	SW42-077	Wiring box	A-Box 040		1	
78	SW42-078	Connector fastener			1	
79	SW42-079	Bolt	M6x25 blue	DIN 933	2	
80	SW42-080	U-washer	M6 blue	DIN 125A	4	
81	SW42-081	Nut	M6 blue	DIN 934	2	

Pos.	Drawing No.	Designation	Dimensions	Standard	Quantity [Pieces]	up to / from serial number
82	SW42-082	Plastic nut	M20x1.5		2	
83	SW42-083	Spiral cable	3 x 1.5 mm ²		1	
84	SW42-084	Power socket			1	
85	SW42-085	Countersunk screw	M5x16 blue	DIN 965	4	
86	SW42-086	U-washer	M5 blue	DIN 125A	4	
87	SW42-087	Nut	M5 blue	DIN 934	4	
88	SW42-088	Cubic plug			2	
89	SW42-089	Rectifier			2	
90	SW42-090	Universal mounting			1	
91	SW42-091	Locking hook			2	
92	SW42-092	Bolt	8x25 blue	DIN 933	4	
93	SW42-093	Locking bolt			4	
94	SW42-094	Nut	M8 blue	DIN 934	4	
95	SW42-095	Nut, narrow	M8 blue	DIN 936	4	
96	SW42-096	Charger, Li-Ion			1	
97	SW42-097	Connector	2.1/5.5 mm		1	
98	SW42-098	Counter bearing 3000	3,000 Nm		1	
99	SW42-099	Bolt			2	
100	SW42-100	Hollow dowel pin 1.4310	6x16	DIN 1481	4	
101	SW42-101	Counter bearing 5000	5,000 Nm		1	
102	SW42-102	Intermediate flange with pump			1	
103	SW42-103	Connection cable			1	
104	SW42-104	Hydraulic tank			1	
105	SW42-105	Electric motor			1	
200	98.03.05 Part No.: 125070	Retaining washer, split (see Pos. 52)	37.2x60x6		2	
201	67.32.104 Part No.: 125073	Profile shaft (see Pos. 51)	KWP1 3/8-6		1	
201	67.32.103 Part No.: 125072	Profile shaft (see Pos. 51)	ZWP1 3/8-21		1	
201	67.32.102 Part No.: 125071	Profile shaft (see Pos. 51)	ZWP1 3/4-20		1	
201	67.32.105 Part No.: 125074	Profile shaft (see Pos. 51)	KWP1 3/4-6		1	
201	67.32.107 Part No.: 129807	Profile shaft (see Pos. 51)	RD35H8 P8 u. P10 Special Accessories		1	
201	67.32.108 Part No.: 129808	Profile shaft (see Pos. 51)	RD40H8 P12 Special Accessories		1	

SPARE PARTS LIST

WALTERSCHEID GMBH

Hauptstraße 150

D-53797 Lohmar

Tel: +49 2246 12-0

Fax: +49 2246 12-3501

www.walterscheid-group.com

WALTERSCHEID